

## Table of contents

1. INTRODUCTION .....	2
1.1. PURPOSE .....	2
1.2. TECHNICAL SPECIFICATIONS .....	3
1.3. DESIGN OF THE DEVICE .....	4
1.4. MAIN MODULES.....	5
1.5. SAFETY DEVICES.....	15
2. INSTALLATION .....	22
2.1. UNPACKING .....	22
2.2. ADJUSTMENTS .....	22
2.3. WITHDRAWAL FROM USE AND STORAGE.....	22
3. FUNCTIONAL DESCRIPTION .....	23
3.1. HANDLING IN ROLL ON – ROLL OFF .....	23
3.2. HANDLING IN TIPPING .....	25
3.3. OPERATION WHEN DRIVING .....	26
3.4. ELECTRICAL SYSTEM .....	27
3.5. HYDRAULICAL SYSTEM .....	29
4. SAFETY INSTRUCTIONS.....	31
4.1. GENERAL .....	31
4.2. WORKING AT EXTREME CONDITIONS.....	33
4.3. ACTING IN DANGEROUS SITUATION .....	33
5. MAINTENANCE / SPARE PARTS .....	34
5.1. MAINTENANCE SCHEDULE .....	34
5.2. MAINTENANCE OPERATIONS .....	35
5.3. SPARE PARTS.....	40
6. TROUBLESHOOTING.....	50

### CONTACT INFORMATION:

Factory:  
 AS FORS MW  
 Tule 30  
 765 05 Saue  
 Estonia

Tel: + 372 679 00 00  
 Fax: + 372 679 00 01  
 E – mail: [info@forsmw.ee](mailto:info@forsmw.ee)

Aftermarket:  
 Language spoken is English and Swedish.  
 FMW Farma Norden AB  
 Hornsväg 2  
 605 97 Norrköping  
 Sweden  
 Tel: + 46 (0) 11 165 770  
 Fax: + 46 (0) 11 128 370  
 E – mail: [aftermarket@forsmw.ee](mailto:aftermarket@forsmw.ee)

## 1. INTRODUCTION

### 1.1. PURPOSE

Bigab hook lift trailers exist in 11 different types of modules with a variety of additional extras which all has its own purpose but with the same unique flexibility. The flexibility lays in its ability to handle different kinds of loads on one and the same chassed. This allows the Bigab to be used at a wide range of different user applications.

Bigab 14 – 17 is the hook lift trailer for the farmer and/or entrepreneur with varying transport needs. The trailer is fully equipped to handle long and hard working hours in the most convenient way. The trailer is possible to combine with lorry transports.

For your safety, it is extremely important that you follow the instructions presented in this instruction manual for your particular BIGAB model.

The unique flexible system gives operators the most cost effective and flexible transport system available. Behind the Bigab trailers lays more then forty year of knowledge and 25 years of product development.

We understand that you are anxious to get to work the trailer, but stop for a bit and take time to carefully read through this instruction book. The Bigab trailer is unique which also if not used properly could turn out to be dangerous. A few moments reading through the instruction book might save you time and money in the future.

We congratulate you at your chose of trailer and wish you and your Bigab all the best for the future!

**FORS MW**  
Fors MW AS

**EG – Försäkran om överensstämmelse med direktiv 2006/42/EG**  
EU-declaration of Conformity 2006/42/EG

**Tillverkare:**  
Fors MW AS  
Tata 39  
76065 Sauer  
Ettland

Den tekniska dokumentationen är sammanställd av Loff Fors;  
The technical file is compiled by Loff Fors;

Företaget intygar att denna uttåtning  
Hereby confirm that this equipment:

1. Fordonstyp/Vehicle type: XXXX
2. Tillverkare/Manufacturer: (XXXX)
3. Serienummer/Chassis number: XXXX
4. Tillverkningsland/Manufacture code: XXXX
5. Tillverkningsår/Manufacture year: XXXX

Är överensstämmelse med direktiv 2006/42/EG och kan användas som en del i en maskin som tillverkas enligt direktiv 2006/42/EG och därför kan användas tillsammans med annan utrustning för att utgöra en komplett maskin.  
Is manufactured according to demands in directive 2006/42/EG and therefore can be used mounted together with other equipment to provide a machine.

Utrustningen får ej tas i bruk förens den maskinen eller utrustningen som den skall ingå i överensstämmer med kraven i EG:s maskindirektiv.  
The equipment can't be used before the machine or the formation that it will take place in, is according to the demands of the EG machine directive.

Signature: *Loff Förs, CEO* Date/Plac: Sauer, 25.11.2009

Tata 39  
76065 Sauer  
Ettland

Telefon: +46 21 479 00 00  
Fax: +46 21 479 00 01  
Reg. no. 14064721

E-mail: info@forsmw.com  
Webb: www.forsmw.com  
S-ACT no. ES-000100001

EU declaration of conformity with Directive 2006/42 EC

## 1.2. TECHNICAL SPECIFICATIONS

Technical specifications.

Table 1.

Hooklift trailer	14-17
Frame:Hollow sections	200*100
Axle distance between wheels:	Axel distance1370 mm
Bogie type:	Bogie with cantilever springs
Hubs:	100*100, 8 bolts
Wheels:	500/50-17
Brake: Hydraulic drum, *Depending on market	300G ×150 on 4 wheels
Towing eyelet:	Type for hitch hook
Support leg: Manual	Hydraulic
Light system:12 volt	yes
Tractor hydraulic equipped with: *For brakes	El on/off, *1 single action
Tractor oil volume:With trailer system filled up	10 L
Oil volume cylinders:	Press 36 L, draw 27 L
Oil flow:	40 – 100L/min
Hydraulic pressure:	22 Mpa
Tipp angle:	48 degrees
Chassi weight (±1%): Standart equipped	3500 kg
Chassi length (±50mm):	5700 mm
Distance eyelet to centred bogie (±20mm):	4370 mm
Distance eyelet to ground surface:	550 mm
Height at skid surface:	1050 mm excluding the hook frame
Wide over tyres (±30mm):	2250 mm
Container length:	4150-4600 mm
Total weight (±1%):	17500 kg
Max load including container (±1%):	14000 kg
Max hooking load including container (±1%):	14000 kg
Pressure on eyelet: depending of lenght of container and load	2500 kg
Max tipping capacity:	14000 kg
Max speed:	40 km/h

### 1.3. DESIGN OF THE DEVICE

The Trailer is constructed out of cold hollow steel sections. Through this construction the trailer receives maximum endurance and stiffness regarding both bending as well as twisting. The trailer is steady both in the tip as well as in the changing movement. The trailer is equipped with a spring suspension pendulum bogie that has been equipped with brakes on all wheels.



Figure 1. Design of the device

## 1.4. MAIN MODULES

The trailer consists of the following subassemblies and functional devices.

### 1.4.1. Chassis

Chassis is constructed out of cold hollow steel sections.

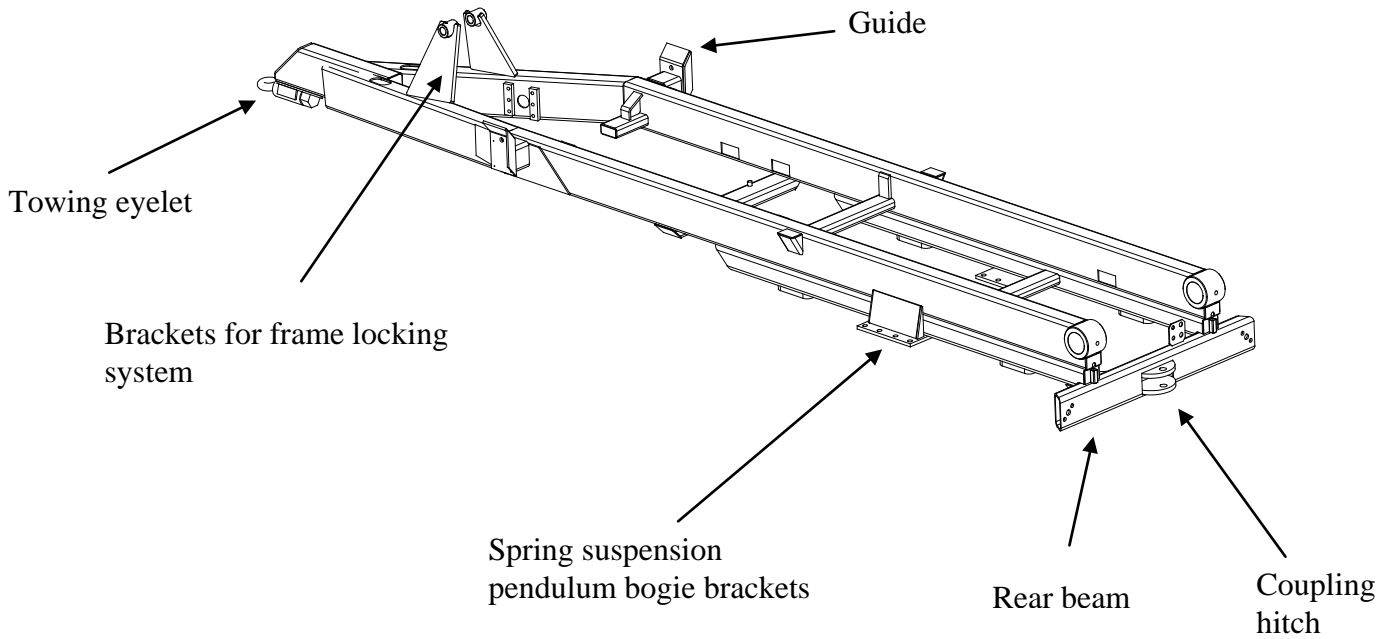

*Figure 2. Chassis*

### 1.4.2. Back frame

Back frame is constructed out of cold hollow steel sections

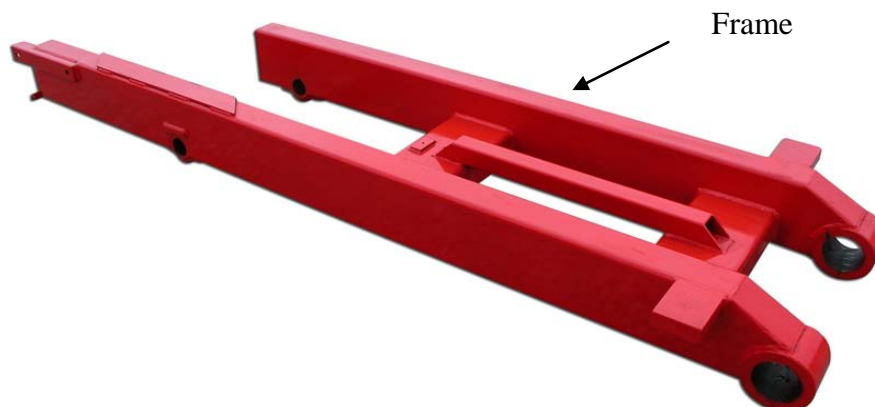

*Figure 3. Back frame*

### 1.4.3. Hook frame

The hook frame is constructed from cold hollow steel sections

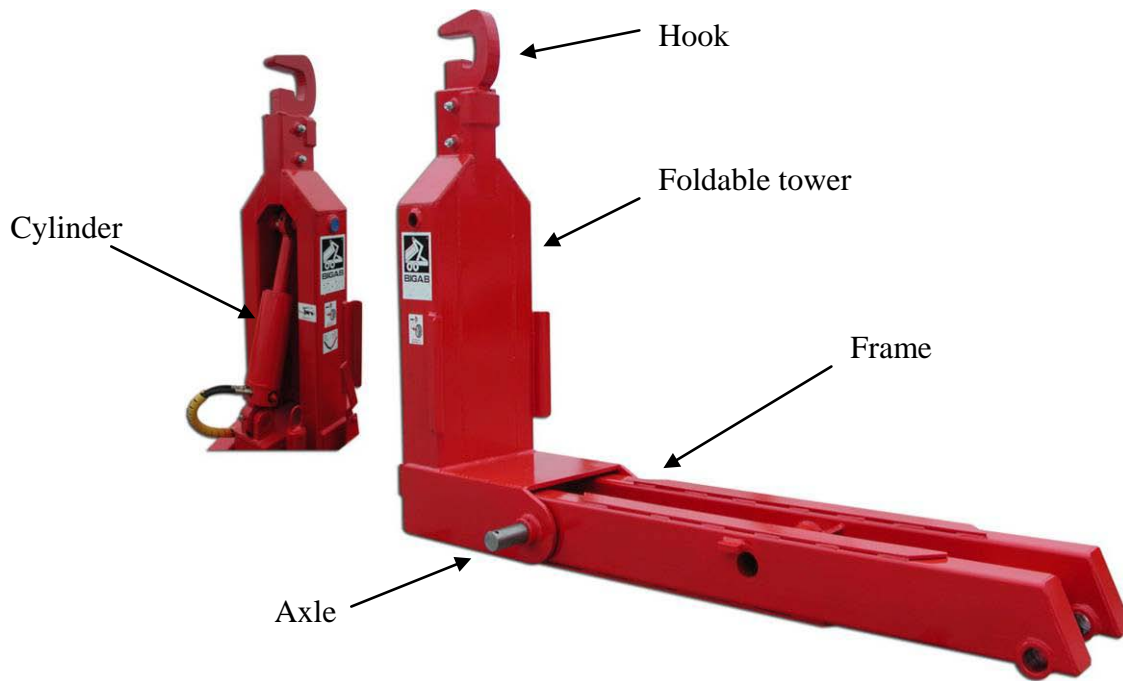

*Figure 4. Hook frame*

### 1.4.4. Bogie

The trailer is equipped with a spring suspension pendulum bogie that has been equipped with brakes on all wheels.

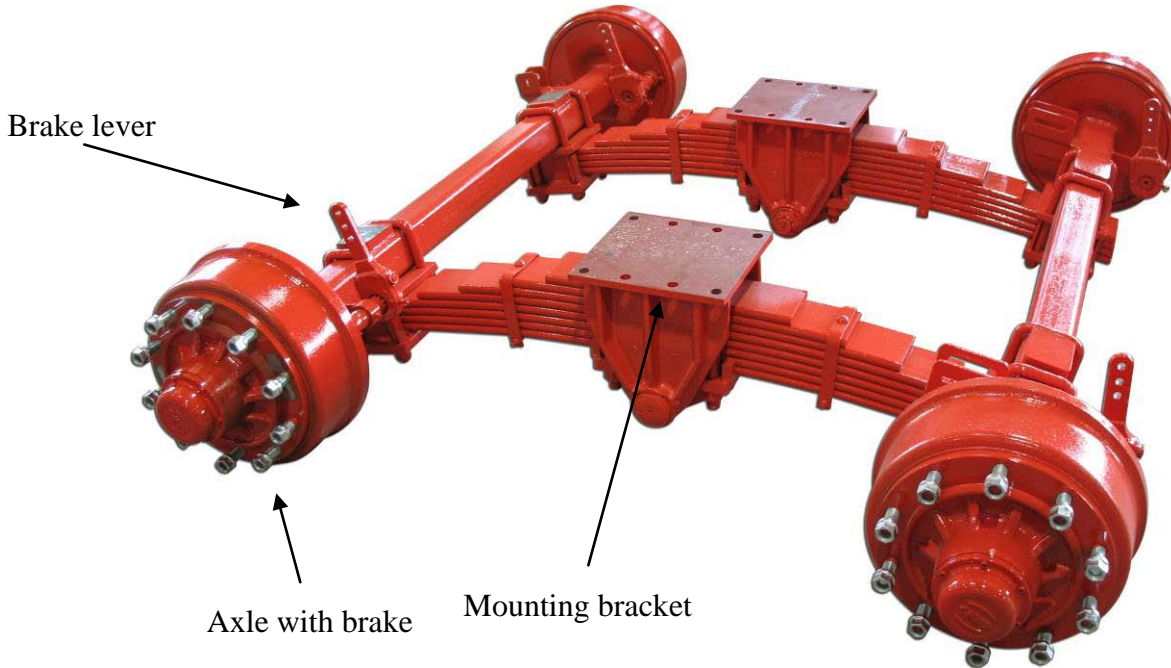

Picture shows : Bogie suspension 20t

*Figure 5. Bogie*

### 1.4.5. Hook

The Trailer is equipped with adjustable hook for two different standard heights.

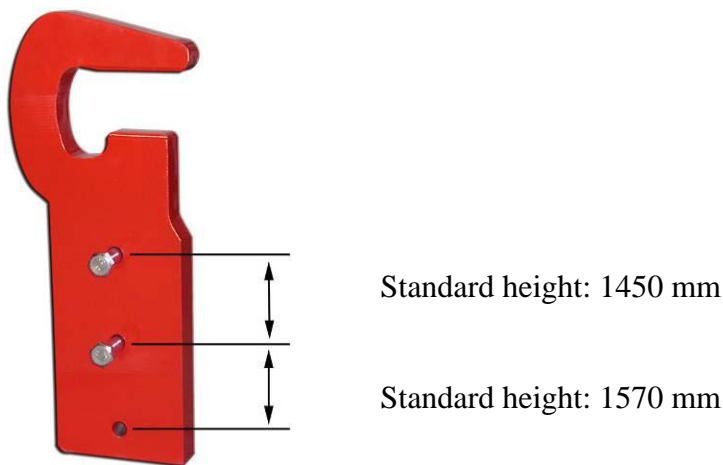

*Figure 6. Hook*

## 1.4.6. Parking support leg

Hydraulic support leg is designed to be of supporting use when the trailer is under maintenance, when trailer is not in use or when connecting / disconnecting trailer. Before driving the support leg must be lifted up and fixed with the pin.

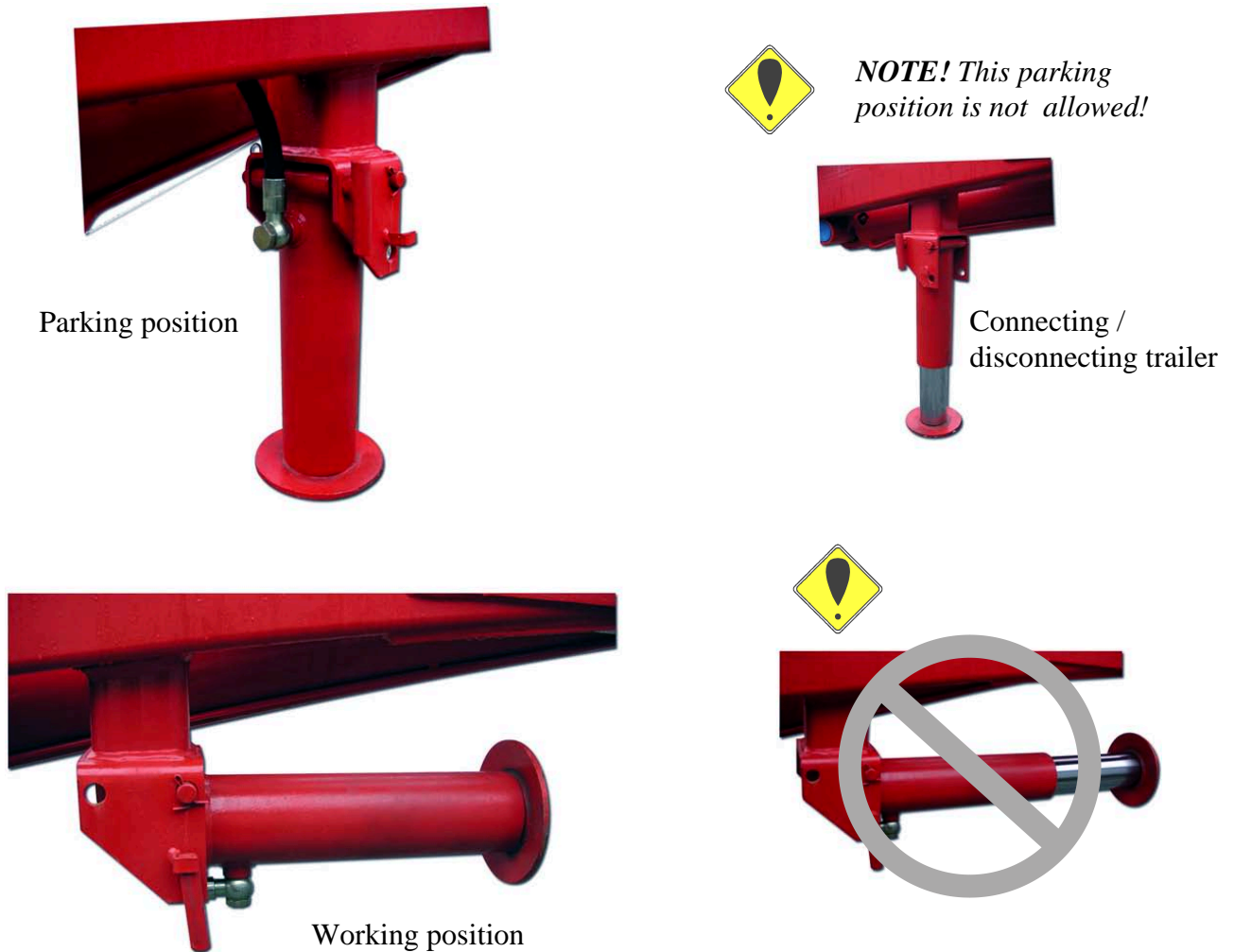

Figure 7. Support leg

### Technical information

Art. No	Type	Length mm	Weight kg	Capacity liter	Working pressure 100 Bar	Working pressure 150 Bar	Max Working pressure 250 Bar
3900295H	3530/85	250	21	1,5	5,67 t	8,5 t	



### 1.4.7. Changing operation unit

This unit is designed for changing operation from rolling on - rolling off to tipping. Unit is located on the left side of the trailer.

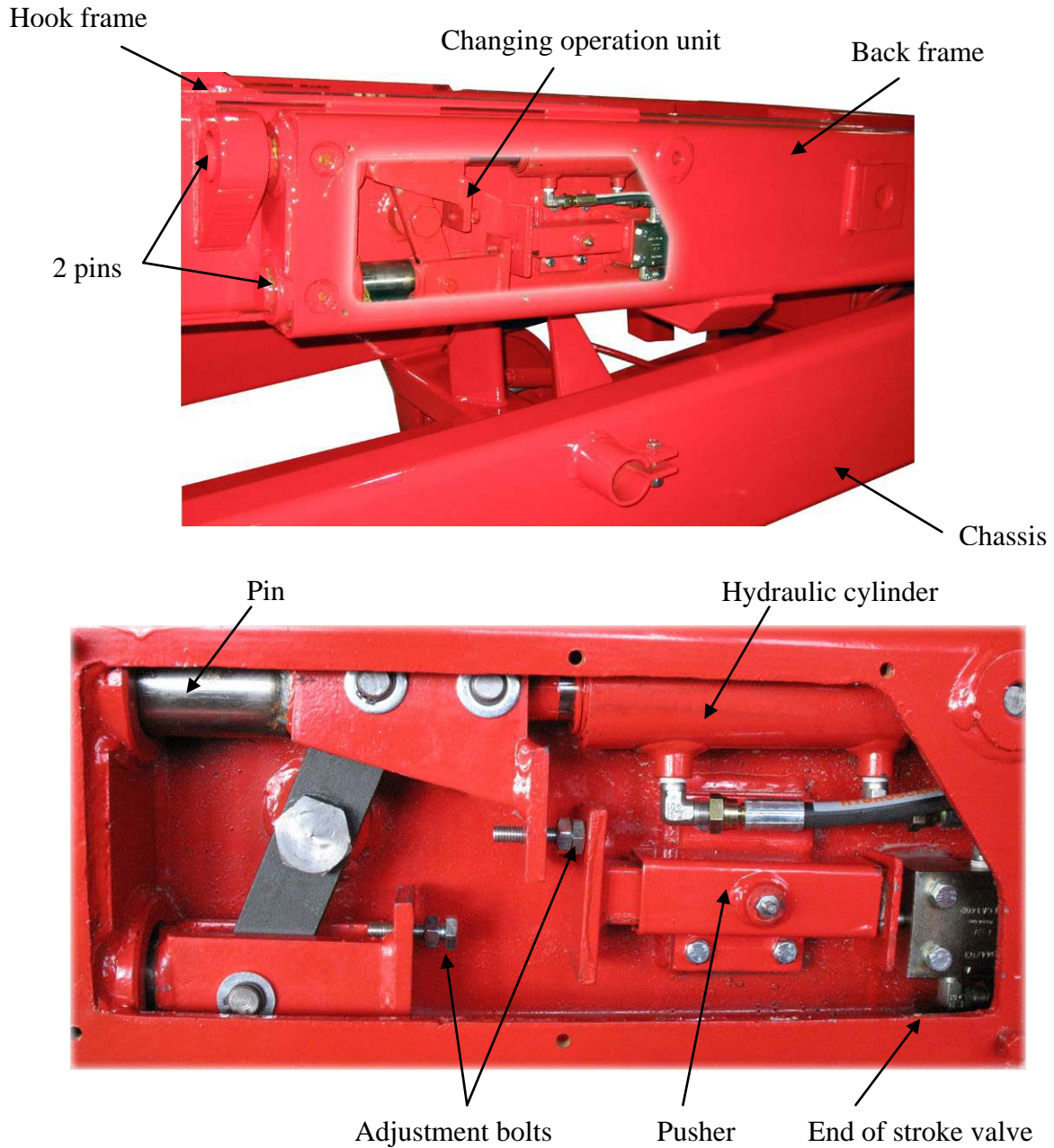
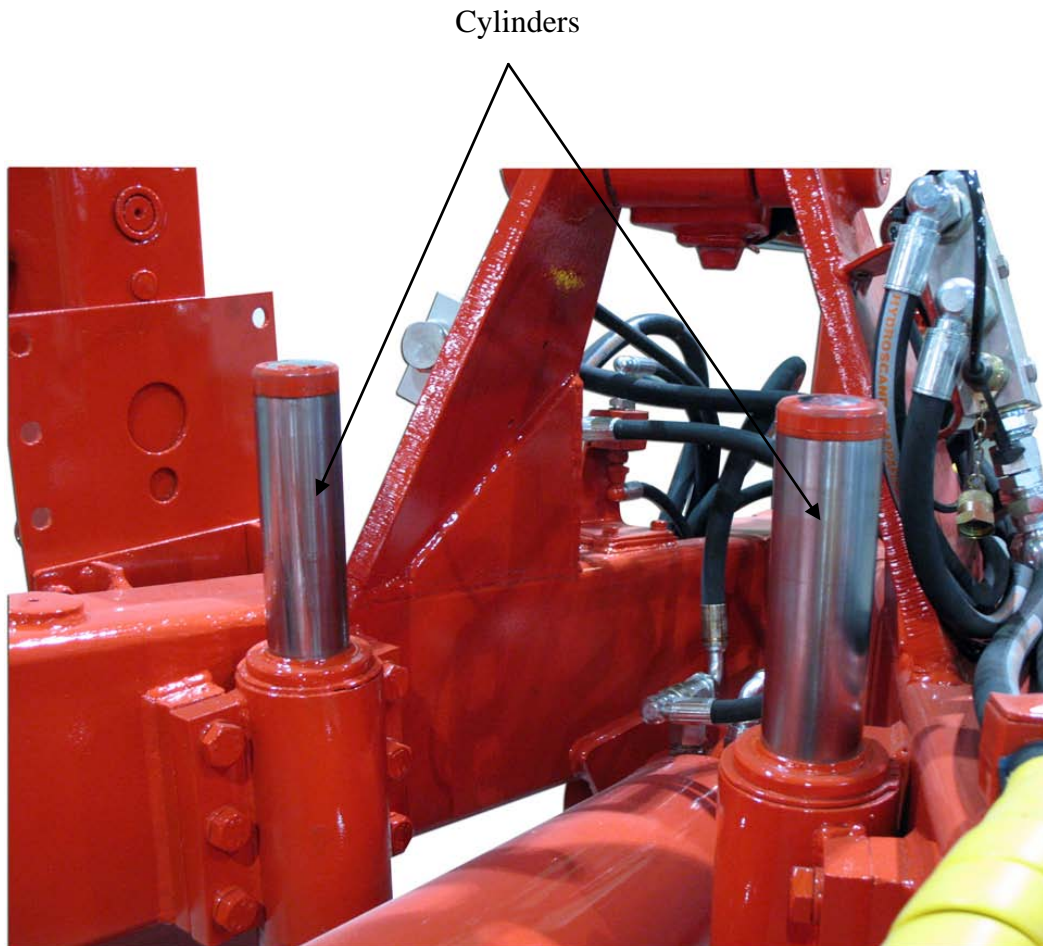

Figure 8. Changing operation unit

#### 1.4.8. Pushing cylinders

The trailer is equipped with two pushing cylinders to maximize the power of the tip and hooking capacity.



*Figure 9. Pushing cylinders*

### 1.4.9. Towing eyelet

The eyelet is used to hitch the trailer to the pulling vehicle. It is **extremely** important that the towing eyelet is checked for defaults every time the trailer is used. The towing eyelet needs to be replaced at least once a year. It is the users responsibility to see to that this is done.

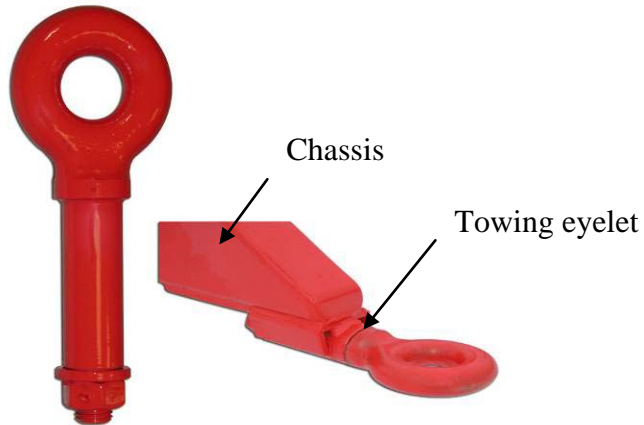

Figure 10. Towing eyelet

### 1.4.10. Coupling hitch

The coupling hitch is used for coupling other trailed devices to the trailer. Coupling hitch is also used for coupling reflector.



Figure 11. Reflector

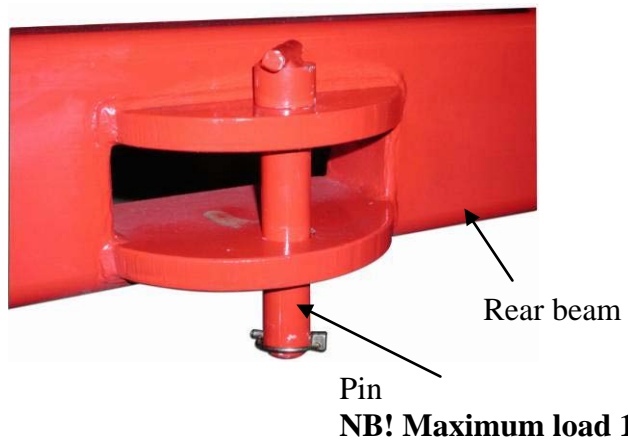

Figure 12. Coupling hitch

### 1.4.11. Steering rollers

The steering rollers are designed to guide the container. During handling roll on – roll off the container frame must be inside the rollers.



Figure 13. Steering rollers

### 1.4.12. Frame locking

The hydraulic frame lock is used to lock the frame during the exchange function. The manometer is present to indicate the tensile force on the cylinder. The manometer is set at 100 bar on delivery, but can subsequently be adjusted either up or down according to the size of the tractor.

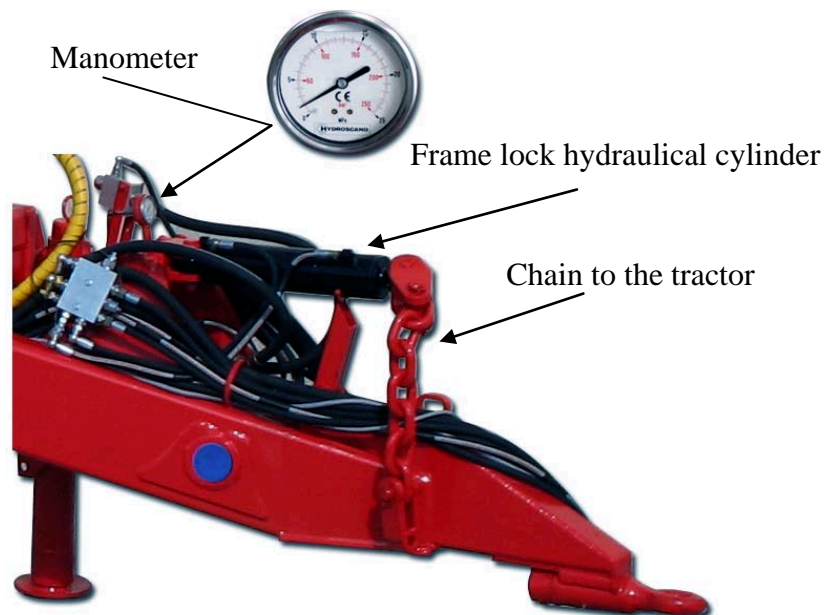

Figure 14. Frame lock

### 1.4.13. Wheels

Wheels for different trailer types

Table 2.

Trailer type	Standard wheel type	Alternative wheel type	Air pressure (bar)	Speed (km/h)
14-17	Wheel 500/50 17		4,3	40

### 1.4.14. Hydraulic system

The trailer is equipped with a hydraulic system for working movements. See chapter 3.4

### 1.4.15. Electrical system

The trailer is manufactured with 12V electrical system. See chapter 3.3

### 1.4.16. Brake system

The trailer is equipped with hydraulic brake system. Also is available pneumatic brake system as an additional extra. The hydraulic pressure in the brake line is not allowed to raise over 16 Mpa. If using too high of a hydraulic pressure the tappet of the brake arm might go from centum and lock the brakes.

### 1.4.17. Electric on-off control unit

The trailer is equipped with hydraulic system witch valves are controlled with electric remote control unit.



*Control unit*

Table 3.

Nr.	Function description
1	Tipping / Rolling
2	Foldable tower / Telescope
3	Changing operation unit
4	Frame Lock
5	Extra
6	Extra



### 1.5.3. Presentation of decals



*Figure 17. Warning triangle and instruction manual decal.*

The trailer is supplied with a warning triangle alongside the instruction manual decal in order to reinforce the requirement for the user to read the entire instruction manual carefully before starting to use the trailer. Ignoring this can entail a danger to life.



*Figure 18. Decal for the use of safety equipment.*

These decals challenge the user to employ appropriate safety equipment in order to avoid injury when using the trailer.



*Figure 19. Risk of clamping injuries*

There is a risk of clamping or crushing injuries during work and maintenance.



*Figure 20. Hazardous area*

Standing between the trailer and the towing vehicle when the trailer is being operated, moved with frame steering or when other functions are activated between trailer and tractor, can be potentially fatal. As the driver, you must always ensure that the area around the machine is free of people.





*Figure 21. Risk of slipping*

There is a risk of slipping as the surfaces of the trailer can be slippery due to precipitation in combination with pre-existing oil and/or clay on the surface. The ground around the trailer can also become slippery, as the tyres can tear up the surface and expose clay and soil.



*Figure 22. Hydraulic fluid under pressure*

Hot hydraulic fluid at high pressure levels can occur in the hydraulic system. Take care when connecting, and replace poor quality hoses.



*Figure 23. Using the exchange unit*

The exchange unit may not be operated unless the frame is folded down. During transport with the trailer, the hook must be folded down in the parking position.



Figure 24. Use the safety support during all service



**Leaning under the raised frame is absolutely prohibited unless it is blocked with the safety support. Under no circumstances may the trailer be carrying either a load or a container when using the safety support.**



Figure 25. Max. load



**It is absolutely prohibited to load more than the amount your model is intended to handle. This can result in danger to you and your surroundings.**



Figure 26. Max. pressure on towing eyelet



**Ensure that you do not load in such a way that the pressure on the towing eyelet exceeds the permitted laws and regulations. The trailer is designed for a maximum pressure of 3,500 kg on the towing eyelet. The pressure is largely determined by the way the load is distributed on the container bridge, and it is the user's responsibility to ensure that this is not exceeded.**



*Figure 27. Tyre inspection*

The tyres must be tightened and the brakes checked regularly at a minimum interval of 40–50 kilometres.

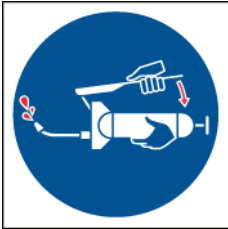

*Figure 28. Lubrication.*

This decal is used to show the importance of regular lubrication of the trailer.



*Figure 29. Data plate*

*Nut tightening torque*

Table 4.

	Thread	Dished discs	Flat discs st 37	Flat discs St52
			Screw Class. 8.8	Screw Class. 10.9
Nuts with spherical collar, conical nuts. Screws with spherical collar.			N.m.	
	M18x1,5	310	330	460
	M20x1,5	-	490	630
	M22x1,5	-	630	740
Flat collar nut with lock washer	M18x1,5	210	270	360
	M20x1,5	-	360	450
	M22x1,5	-	460	550
Nut with flat seat captive washer	M18x1,5		260	360
	M20x1,5		350	500
	M22x1,5		450	650
Screwed connection disc/rim on track adjustable wheels	Thread	Flat discs		
		Screw Class. 8.8		
	M18x1,5	260-330		



Figure 30. Lubricate points.

All of the hydraulic hoses of the trailer are marked with coloured labels. See table below for more detailed information. Functions depend of the hydraulic system configuration.

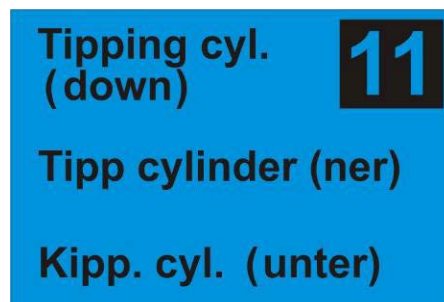

Figure 31. Hydraulic hose label (example tipping cylinder)

Hose label colours:

- Red - oil from pump.
- Blue - oil connected direct to tank.
- Yellow - Brake

Marking for hydraulic hoses tractor controlled

*Table 5.*

No.	Colour mark	Function
1	Yellow	Brake
20	Red	Bogie-lift ( on )
21	Blue	Bogie-lift ( off )
22	Red	Extra port ( a )
23	Blue	Extra port ( b )
24	Red	Rear tailgate ( a )
25	Blue	Rear tailgate ( b )
26	Red	Steering control ( p )
27	Blue	Steering control ( t )
28	Blue	Straight steering control (t)

## **2. INSTALLATION**

### **2.1. UNPACKING**

Before unpacking, check visually that the trailer is not damaged during transportation. If the trailer is damaged, inform about this to the company that transported the trailer and the manufacturer of the product immediately.

- Usage of the trailer is strictly forbidden if safety devices of the trailer are damaged. For more detailed information about safety devices see 1.5
- When you are unpacking the trailer be careful: do not damage sensitive components, do not change factory settings or damage paint or other surface finishes.
- Lift up the trailer from transportation frame.
- Lower the trailer to the floor.
- Be careful when lifting so that cables, connectors or other components are not damaged for instance between lift work and trailer frame.
- Weight depends see technical information for data.

### **2.2. ADJUSTMENTS**

Quick couplings are used in the operation of connecting the vehicle in use with the trailer. These couplings serve to disconnect the hoses without their breakage and to prevent loss of oil under accidental strain and pull.

### **2.3. WITHDRAWAL FROM USE AND STORAGE**

- It is not allowed to store the trailer in a cold and/or damp environment for a long period.
- All metal parts are recyclable and should when time comes be handed over to a recycler.

## 3. FUNCTIONAL DESCRIPTION

### 3.1. HANDLING IN ROLL ON – ROLL OFF

If your BIGAB is equipped with suspension there is no bogie blocking.

Exchange and tipping must be operated from the operator's seat in the towing vehicle!

Figure 1

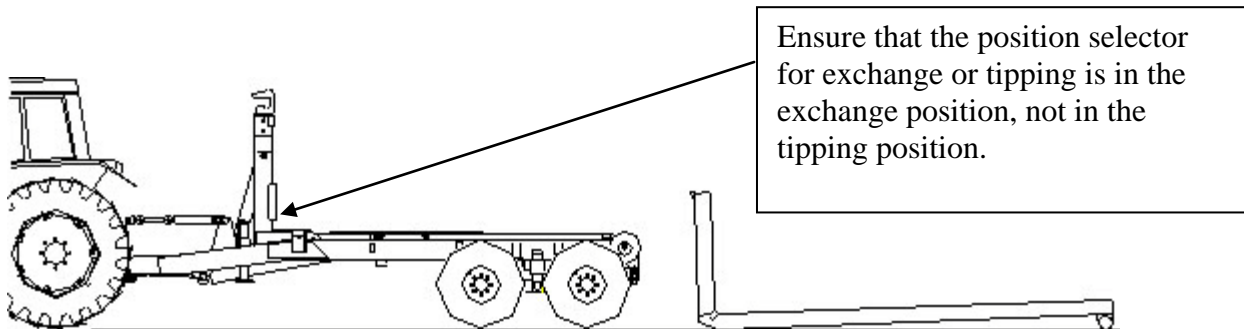
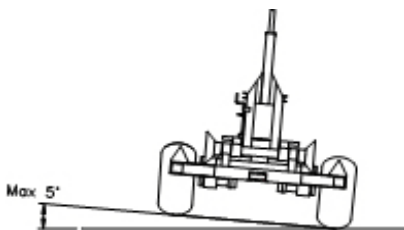

Figure 2



Place the hooklift trailer on a flat surface. The sideways incline may not exceed 5 degrees.

**Failure to read this instruction manual can be potentially fatal!**

Under no circumstances may you reverse/exert pressure with the towing vehicle in order to facilitate exchange. This entails an immediately risk of the trailer or the towing vehicle being damaged, which can be potentially fatal. The load must be pulled on and the trailer and the towing vehicle must roll in under the freely suspended load.

Figure 3

**STOP**  
Stop if the tractor lifts off the ground!

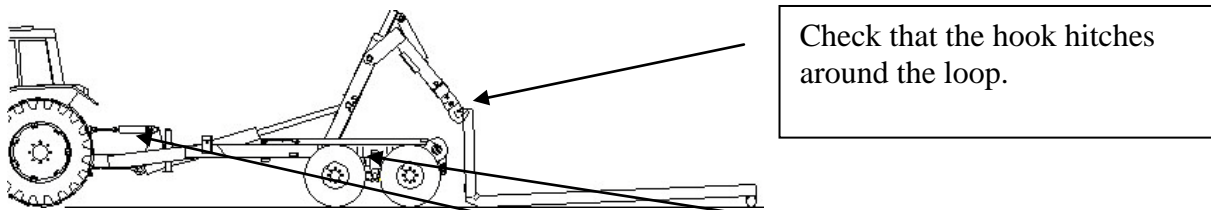

Check that the frame lock and bogie blocking are activated.

**On-loading!**

- Check that the load carrier is inside the discs. Release the brakes on both the towing vehicle and the trailer to make it easier to roll on the load. Check the position of the tower during on-loading so that the container bridge's frame does not catch on the rollers from behind.
- The tower must be fully retracted when rolling on the container bridge in order to increase lifting force and reduce the strain on the towing eyelet. Ensure that the container frame does not catch in the rollers at the back of the trailer. Adjust the tower upwards continually during exchange in order to move past the rollers. If the tower is not adjusted upwards during on-loading, there is a considerable risk of the exchange's lock being damaged if the container frame catches in the rollers.

**IMPORTANT!** Follow the movement with the retractable tower so that the front of the hooklift trailer's frame does not catch on the rollers. When you have passed the rollers, always keep the hooklift trailer's frame close to the rollers.

Figure 4

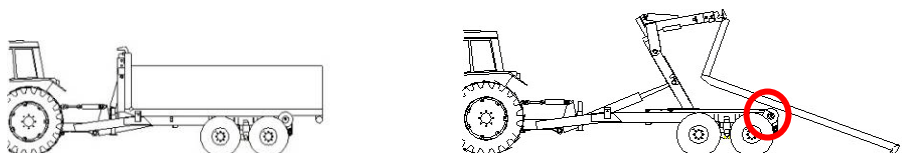

**Off-loading!**

Release the brakes on both the towing vehicle and the trailer to make it easier to roll off the load. Check the position of the tower during off-loading so that the container bridge's frame does not catch on the rollers from above.

Lock the frame and activate bogie blocking between the towing vehicle and trailer.

1. Raise the hooklift frame slightly so that the container bridge does not scrape against the frame when off-loading the container bridge.
2. Then retract the tower so that the locking rails/wings on the container bridge frame move freely and cannot be damaged.
3. Adjust the tower upwards continually so that the container frame does not catch on the rollers at the back of the trailer during off-loading.
4. If the tower is not adjusted upwards during off-loading, there is a considerable risk of the exchange's lock being damaged if the container frame catches in the rollers.



## 3.2. HANDLING IN TIPPING

**Note!** For the models mentioned in this instruction manual, the maximum container bridge length is 4,6 m during tipping. Ensure that the towing vehicle and the trailer are securely coupled before tipping.

Figure 1

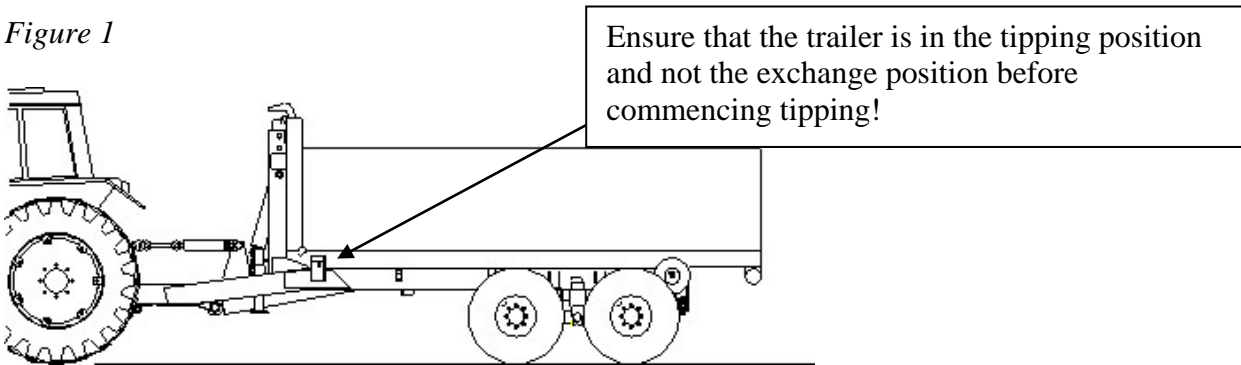
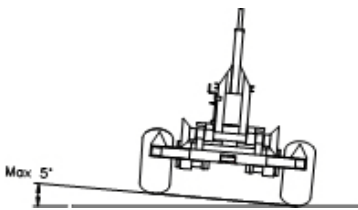

Figure 2



Place the hooklift trailer on a flat surface. The sideways incline may not exceed 5 degrees.

Figure 3

At maximum tipping – drive slowly forwards until the container bridge is empty. Lower the container bridge before continuing to drive. Important! Ensure that the container bridge is locked in the correct position before driving.

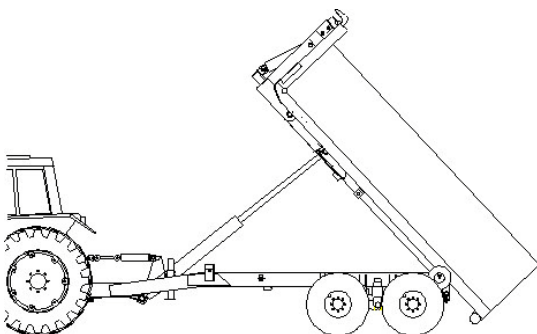

### **IMPORTANT!**

When tipping, use the brakes to ensure that the machine does not roll away when the load slides off.

### 3.3. OPERATION WHEN DRIVING

It is the responsibility of the user to ensure that a sufficiently powerful and heavy towing vehicle is coupled to the trailer in all situations. The use of a towing vehicle that is too small and insufficiently powerful can entail risks for the user and the surrounding environment, as well as leading to damage to the vehicle and trailer.

Load\* (excl. the container's dead weight)

Load	Kg/m <sup>3</sup>	Full container 7 m <sup>3</sup>	14 m <sup>3</sup>	21 m <sup>3</sup>	27 m <sup>3</sup>
Peas, Wheat, water content 15%	800	5,600 kg	11,200	16,800	21,600
Rye, water content 15%	750	5,250 kg	10,500	15,750	20,250
Barley, water content 15%	680	4,760 kg	9,520	14,280	18,360
Oats, water content 15%	560	3,920 kg	7,840	11,760	15,120
Silage, newly harvested	850	5,950 kg	11,900	17,850	22,950
Macadam	1400	9,800 kg	19,600	29,400	37,800
Gravel	1550	10,850 kg	21,700	32,550	41,850
Clay	1800	12,600 kg	25,200	37,800	48,600
Wood chips (50% moisture content)	350	2,450 kg	4,900	7,350	9,450

\*The higher the moisture content of the load, the heavier the load, a fact that the user has to take into consideration. This table is only an approximate estimate of the weights that can occur, and it is the responsibility of the user to ensure that the vehicle's limits and the applicable legislation are not being exceeded. The specified values are not exact values, just examples.

Figure 32. Example of weight with different types of load

For information purposes and for examples of how much different loads can weigh, please refer to the above table. This table should only be viewed as guidance and information. The manufacturer cannot be held responsible for dimensions or volumes specified in the table, and the table may only be viewed as a recommendation.

#### 3.3.1. Load on towing eyelet and coupling

Always adapt your driving to the load, road conditions and your level of experience. Do not exceed the maximum speed specified for the trailer. Ensure that you have the correct pressure on the tow hook when you are driving. Ensure that you do not exceed the intended upwards and downwards pressures on the trailer's towing eyelet and the coupling to the hook device. The given ideal conditions and theoretical calculations indicate the following maximum load values, and it is recommended that the user observes these load values.

Max. load upwards in kg

BIGAB 14 - 17                      3400kg

Max. load distributed evenly over the container.

Max. load downwards in kg

BIGAB 14 - 17                      2400kg

## 3.4. ELECTRICAL SYSTEM

### 3.4.1. Basic electrical system

The trailer is manufactured with 12V electrical system. Configuration depends of options, example reversing light, border light or additional cable connector.

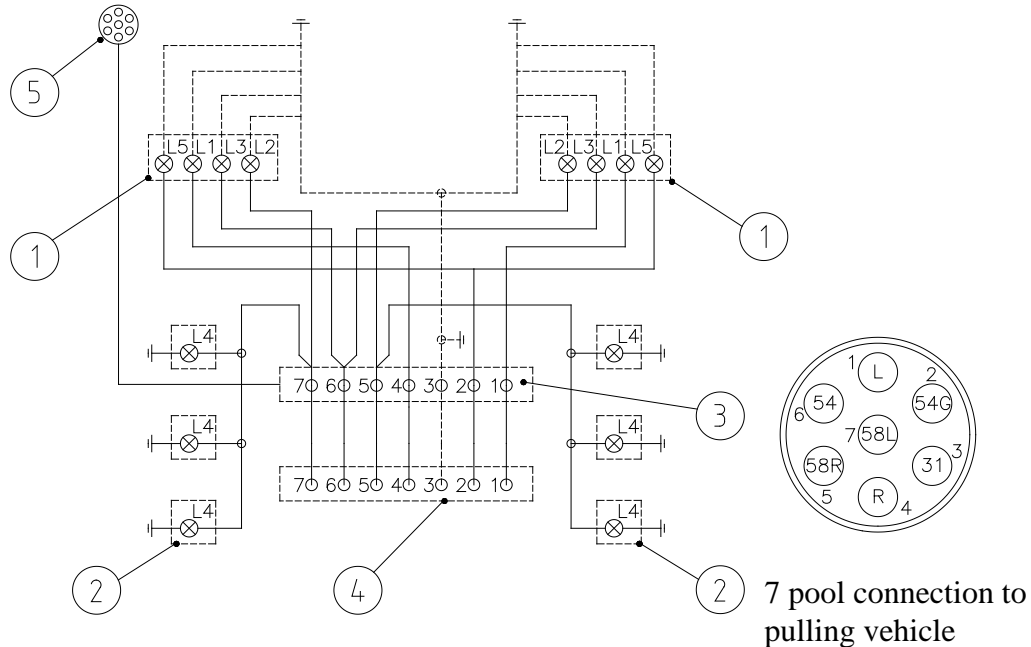

Figure 33. Electrical diagram

Electrical components.

Table 6.

Pos.	Art. No.	Title
1	920764L/R	Rear light - left or right
1	920766L/R	Rear light with reversing light – special – left or right
2	920770	Border light 111x40 (orange) - special
3	920715	Cable terminal
4	920695	Cable Connector 7 pools (male)
5	920180	Cable Connector 7 pools (female) -special

Connections of the cables and lamps.

Table 7.

Nr.	Color	Function	Lamp
1	Red	Flashing left	12V-21W (L1)
2	Brown	Reversing light	12V-21W (L5)
2	Brown	Spare (without reversing light)	
3	Yellow	Earth	
4	Blue	Flashing right	12V-21W (L1)
5	Grey	Rear right	12V-21W (L2)
5	Brown	Side marking	12V-5W (L4)
6	Black	Brake light	12V-10W (L3)
7	Green	Rear left	12V-21W (L2)
7	Brown	Side marking	12V-5W (L4)

### 3.4.2. Electrical on - off system

The electrical on-off is manufactured with 12V electrical system. Configuration depends of options.

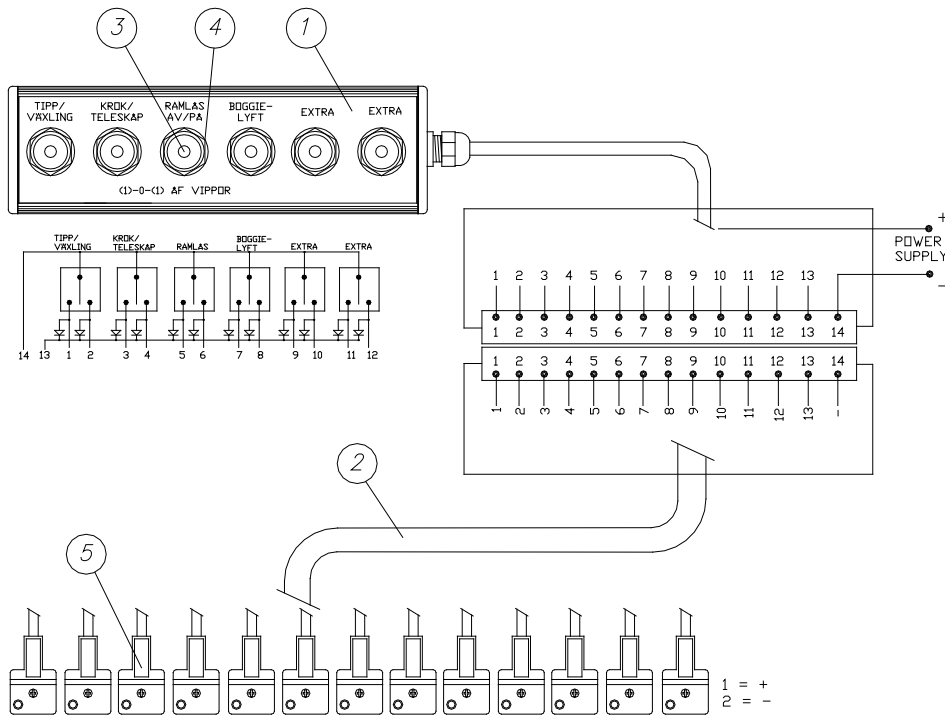

Figure 34. Electrical diagram

Table 8.

Pos.	Art. No.	Title
1	915181E	Electric on-off control unit
2	91581CS	Cable set
3	91581ES	Electrical switch
4	91581RP	Rubber protection
5	915181CC	Cable connector

## 3.5. HYDRAULICAL SYSTEM

### 3.5.1. Main hydraulic system

The trailer is delivered with filled up and tested hydraulic system. The hydraulic system consists of the functional components showed in the figure below. Technical data and configuration depends on the type of trailer (*see table 1*). The hydraulic system is filled up with hydraulic oil VMGZ or SAE100R16. It is applied as a working fluid of the hydraulic systems for operating in the open air at temperatures ranging from  $-50^{\circ}\text{C}$  up to  $+60^{\circ}\text{C}$  at a continuous operation service. For maintenance of the hydraulic system see chapter 5.

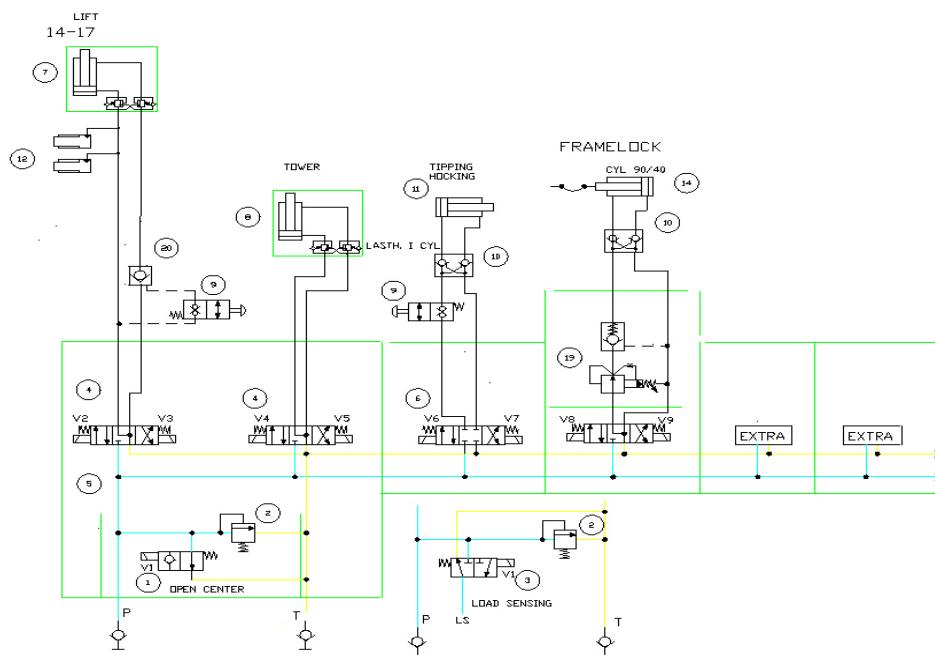

Figure 35. Hydraulic system.

Hydraulic components

Table 9.

Pos.	Art. No.	Title
1	940810	Release valve
2	940815	Security valve
3	940820	Logic valve
4	940825	4-way valve
5	940830	Valve block
6	940835	4-way valve
7	913265	Tipping / Rolling cylinder with pilot operated valve
8	913240	Tower cylinder
9	913640	End of stroke valve
10	915201	Pilot operated double check valve VBD-L-38
11	913230	Operation changing cylinder
12	17-100100.00	Pushing cylinder
14	313135	Cyl. 90x40-300 Frame lock
18	913210	Brake cylinder 40/25-55
20	915200	Hyd valveblock VB1225-12 + valve

### 3.5.2. Frame lock hydraulic system

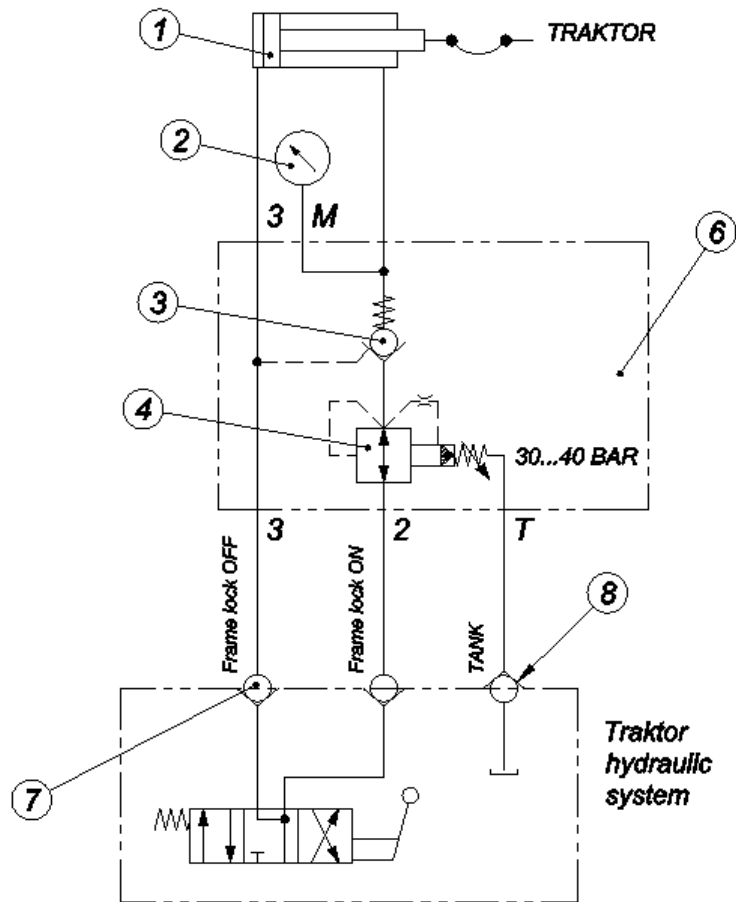

Figure 36. Frame lock hydraulic system.

Hydraulic components for frame lock

Table 10.

Pos.	Art. No.	Title
1	313134	Cylinder 90/40-300
	37313942	Seal kit for hydraulic cyl. 90/40
2	915275	Manometer
3	915271	Pilot operated check valve
4	915266	Pressure reducing/relieving valve
6	915265	Manifold
7	914570	Bayonet coupling male
8	9145702	Bayonet coupling female

## 4. SAFETY INSTRUCTIONS

### IMPORTANT:



READ AND UNDERSTAND THE USER MANUAL CAREFULLY BEFORE USING THE DEVICE. CONSULT THE USER MANUAL TO SOLVE YOUR PROBLEMS. THE DEVICE HAS AN IDENTIFICATION LABEL ON IT. BEFORE USING THE TRAILER, ENSURE THAT FACTORY SETTINGS HAVE NOT CHANGED AND THERE ARE NO PARTS LOOSEN DURING TRANSPORTATION. MAKE SURE THAT ALL WARNING SIGNS AS WELL AS LABELS AND TAPES ARE IN THE APPROPRIATE PLACES.

THE DRAW EYELET MUST BE CONTROLLED FOR DEFAULTS EVERY TIME BEFORE THE TRAILER IS USED. THE DRAW EYELET NEEDS TO BE CHANGED AT LEAST ONCE A YEAR. IT IS UP TO THE USER OF THE TRAILER TO SEE IT THAT THIS IS DONE.

### 4.1. GENERAL

#### Before you start to work:

- Carefully examine the trailer.
- Check that all joints are connected tightly.
- Check that the trailer is located on hitch hook.
- Check the draw eyelet for defaults.
- Control brakes.
- Control the lights.
- Check that the brakes are functioning.
- Check that hydraulic hoses and couplings are intact and free from cracks.
- Check that all hydraulic functions are working.
- Remember that it is not allowed to use this unit for functions not confirmed by producer.
- Be aware that a long container needs enough working space and turning area.
- Respect the safety distance.
- Never stand by the drawbar when connecting and disconnecting or when functions between the towing vehicle and trailer are activated.
- Be sure that nobody is in the working area of the trailer.
- Do not exceed maximum loading values
- Always engage the base machines parking brakes before loading. If necessary put some obstacles in front of wheels
- Study safety instruction.

#### During maintenance:

- Be sure that the trailer is standing on a flat surface.
- Be sure that the trailer can't move.
- When lubrication or servicing the trailer, turn off the vehicle engine.
- Be sure that the trailer can't slip when using support leg, jack or similar equipment.

- Always use the security post in tipping position when servicing. The safety support must always be used when carrying out service work in the tipped position. There must not be any load on the trailer when carrying out service work in the tipped position. See figure below.
- Never attempt to do maintenance work on the hydraulic system before you are sure there is no pressure.
- Do not tighten or repair leaking hydraulic couplings while the system is pressurized.
- Never attempt to localize a leakage from hoses or connections by feeling with hand. The high-pressure oil jet can penetrate skin and cause serious burns and damages. High-pressure oil is also highly flammable.
- Avoid getting oil into eyes. Use safety goggles and gloves. If oil has got into eyes flush them with cool water and immediately contact a doctor.



Figure 37. Safety

**Note!**

**It is strictly forbidden to lean under the container body without using the security post!**

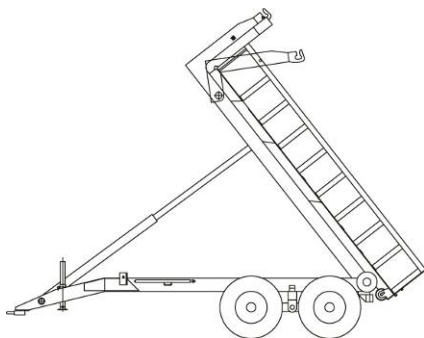

Figure 38. Raised container bridge



**Never drive under obstacles such as bridges, electrical cables, etc., with the container bridge raised.**



## **Driving:**

- Don't forget to lift the support leg up before driving.
- Do not exceed maximum travel speed.
- Never make sharp turns at great travel speed.
- Long container needs enough working space and turning area.
- Do not exceed maximum loading values
- Be sure that the container is firmly fixed before driving.
- Recommended load placement - symmetrical.

## **4.2. WORKING AT EXTREME CONDITIONS**

Recommended working temperature range for a Bigab trailer is  $-30^{\circ}\text{C}$  up to  $+40^{\circ}\text{C}$ .

Note that working at low temperatures accelerates hydraulic gaskets wearing and increases hydraulic hoses exposure to damages and steel constructions exposure to brittle fracture. When working at lower temperature than recommended, lift lighter loads than usual.

Before starting to work in cold conditions let the oil circulate freely through the system a few minutes. Slowly work every action through several times so that gaskets come pliable before they receive full pressure.

At exceptionally warm conditions beware of hydraulic oils excessive heating. Too high oil temperature (higher  $+80^{\circ}\text{C}$ ) degrades oil and damages gaskets.

## **4.3. ACTING IN DANGEROUS SITUATION**

**If the trailer comes into contact with high voltage electric wires comply with the following instructions:**

### **IF YOU ARE OUTSIDE THE MACHINE**

Do not attempt to get into the machine. Keep everybody out from the machines vicinity. Do not touch any part of machine.

### **IF YOU ARE INSIDE THE MACHINE**

Get out of it by **JUMPING**. Avoid touching any conducting parts. Do not make yourself a wire through which electricity may flow. Get away from the machine by **JUMPING** so that both feet do not touch the ground at the same time. Electric field at ground can cause fatal voltage between legs. At about 20 meters away you should be safe but this is of course a questions of circumstances.

## 5. MAINTENANCE / SPARE PARTS

### 5.1. MAINTENANCE SCHEDULE

All kinds of maintenance work are subdivided into two groups: operating (preventive) and compulsory (scheduled).

The need for operating maintenance is determined based on the results of checking.

#### General

- Maintenance works must be carried out regularly to ensure safe and malfunction-free operations.
- Maintenance works does not require any special tools. The user can perform most of the operations.
- Use correct tools.
- Attempt to localize the defects as clearly as possible; you should have to avoid opening the system unnecessarily.
- Keep disassembled parts and repair area protected from dirt.
- Keep spare parts in their packages until needed for installation.
- Valve adjustments and repairs are recommended to be handled by service personnel.

#### Daily inspections:

- Examine visually the loader. Note defects and failures that might affect safety. Repair possible defects and failures.
- Check so there is no leakages on hydraulic system, or damaged hoses.
- Work through every function to its extreme position.
- Check the oil level.

#### Weekly maintenance:

- Clean the trailer regularly with sponge and soap.
- When cleaning never use hot water under high pressure, it will remove the grease from bearings.
- Check the operation of the device.
- Check hydraulic pressure.
- Check the brake condition.
- Control wheel nut tightness. When tightening the locking force must be 330-370 Nm.
- Check the lights, reflectors and bulbs.

#### Monthly maintenance:

- Check the air pressure in tires.
- Check if there is enough lubricant on glide surfaces.
- Clean and lubricate hydraulic cylinders.
- Check hydraulic hoses for damages.

**Recommended lubricants:**

BRAND	TYPE
BP	Energrease LS-EP2, L2M
ESSO	Beacon EP2, Multipurpose GR Moly
MOBIL	Mobilux EP2, Mobil Grease MP Special
SHELL	Alvania EP Grease 2
UNION/TEXACO	Marfak Multi-Purpose 2, Molytex Grease 2

## 5.2. MAINTENANCE OPERATIONS



**IMPORTANT:**

BEFORE MAINTENANCE AND SERVICE OPERATIONS READ AND UNDERSTAND THE SAFETY INSTRUCTION.

**During maintenance:**

- Be sure that the trailer is standing on a flat surface.
- Be sure that the trailer can't move.
- When lubrication or servicing the trailer, turn off the vehicle engine.
- Be sure that the trailer can't slip when you using support leg, jack or similar equipment.
- Always use the security post in tipping position when servicing.
- Never attempt to do maintenance works on the hydraulic system before you are sure there is no pressure.
- Do not tighten or repair leaking hydraulic couplings while the system is pressurized.
- Never attempt to localize a leakage from hoses or connections by feeling with hand. The high-pressure oil jet can penetrate skin and cause serious burns and damages. High-pressure oil is also highly flammable.
- Avoid getting oil into eyes. Use safety goggles and gloves. If oil has got into eyes flush them with cool water, after contact the doctor.

### 5.2.1. Surface cleaning

Remove accumulated dust and dirt. Painted outer surfaces should be cleaned regularly with sponge and soap. When cleaning never use hot water under high pressure, it will remove the grease from bearings.

### 5.2.2. Maintenance of the hydraulic units

Hydraulic system is shown in chapter 3.5.

- Clean and lubricate piston rods of hydraulic cylinders.
- Check the hydraulic valves:  
Check visually hydraulic valves. In case of leaking replace the damaged valve.
- Check hydraulic hoses:

Check visually hydraulic hoses and union pipe connections. Replace a hose in case of leaking or if there are ruptures or slashes on it.

- Check the level of oil, add and replace oil.
- Check the operation of the device.

When replacing hydraulic components such as hoses, gaskets etc, make sure they correspond with original parts. To avoid malfunctions and ensure safe operation use original spare parts.

### **Changing the seals**

Change all cylinder seals at the same time. The piston cannot be split. The seals must be slipped over the piston edge. Be careful not to break the seals when fitting them in place.

- After removing the old seals clean the grooves carefully before fitting the new seals into place.
- Lubricate the new seals with hydraulic oil.
- Open the pistons lock nut.
- Screw the piston off.
- Withdraw the guide piece from the rod.
- Change the guide piece seals; make sure that the piston rod seal is the right way round, i.e. the lip against the pressure.

**NB: Never operate the hydraulic system with the level of oil dropping below lower mark.**

### **5.2.3. Maintenance of the pneumatic units**

- Clean and lubricate piston rods of pneumatic cylinders.
- Emptying the water collector:  
Condensed water is removed from the air tank located in the side of trailer.
- Check the pneumatic valves:  
Check the pneumatic valves by listening to the working sound. In case of leaking replace the damaged valve.
- Check pneumatic hoses:  
Check visually pneumatic hoses and union pipe connections. Replace a hose if there are ruptures or slashes on it.
- Check the operation of the device.

### **5.2.4. Maintenance of the electrical components**

The trailer is manufactured with 12V electrical system. Electrical system is shown in chapter 3.4.

The wires to the electrical equipment are of different colours, which facilitate the location of the wire leads connecting individual items of the electrical equipment. Refer to the electrical diagram (figure 3.4) to ensure a correct subsequent reconnection of the electrical units and also when checking the operation of the equipments and individual electric circuits.

- Clean and check the lights:  
In case of fault replace the lamp. If the lamp keeps on braking repeatedly, find out the cause of the matter.
- Check electrical connectors:  
Clean them of dirt and dust.
- Check wires insulation:  
Check wire insulation, wire joints and protection of insulation against rubbing during jolting and contacting the trailer parts. Protect the wires from oil and fuel, which ruin insulation. Wipe dirty wires.

**NB: Join and disjoin plug connectors only with dead circuits.**

### 5.2.5. Maintenance of the brake system

The trailer is manufactured with a hydraulically functioned brake system. Air brake system with negative or positive action is optional.

Control the brakes regularly. Test the brakes at least once per week while trailer is working.

See to it that no lubricant penetrates into the brakes. Any lubricant, which has penetrated the brake, causes greasing of the disks, thereby reducing friction between their working surfaces. A poor operation of the brakes is the result of such happening. In such a case dismantle the brake, eliminate the oil leakage, wash the greasy disks with gasoline and let them dry out.

Control always the brake control linkage after the drum being dismantled, adjust if needed.

For adjusting the brakes you need to lift up the bogie-frame from the ground and adjust the brake levers. You do this by spinning the wheel while adjusting. The brakes are correctly adjusted when they spin freely without any scraping noises from the wheel. After all kinds of adjusting in regards to the brakes, always carry out a practical brake test before driving away.

If the brakes seem to work grainy, found the brakes, pull the trailer maintaining low speed for a couple of hundred meters, try again through braking the vehicle while driving in a normal speed. Keep on reiterate until the brakes functional normally. If necessary contact our service department!

BIGAB models 7 – 10, 8 – 12 and 10 – 14 – the brake shoe distance to the drum needs to be adjusted through loosening and by doing so adjusting the brake control linkage.

BIGAB models 12 – 15, 15 – 19 and 20 – 24 – the brake shoe distance to the drum on the brake cylinder needs to be adjusted through loosening or vice versa tightening the adaptable screw on the brake.

### 5.2.6. Maintenance of wheels

The maintenance of the wheels before proceeding to work consists in watching over the condition of the threaded joints and timely tightening there of and in observance of the rules for use and maintenance of tires.

- Check the threaded joints.
- Check the pressure of air in the tires.

Wheel pressure

Table 11.

Trailer type	Standard wheel type	Alternative wheel type	Air pressure (bar)	Speed (km/h)
14-17	Wheel 500/50 17		4,3	40

### 5.2.7. Maintenance undercarriage

#### Every day

It is necessary to visually check the nuts on the bogie side each time the customer uses the trailer.

#### Weekly

Once per week (or not later than 20 hours) it is needed to lubricate the grease nipples. You need to lean under the trailer to be able to grease the glide bearings. This will be easier to do if the trailer is without load.

### 5.2.8. Lubrication

Recommended lubrication cycle is once per week or after 20 working hours. Lubricate points equipped with grease nipples by using a grease gun. See chapter 5.1 for recommended lubricants.

- Ensure regularity of lubrication by following the lubricating schedule.
- Keep flammable material away from heat, sparks and open fire.
- Do not let oil run into the nature. Oil spilled into ground pollutes environment.

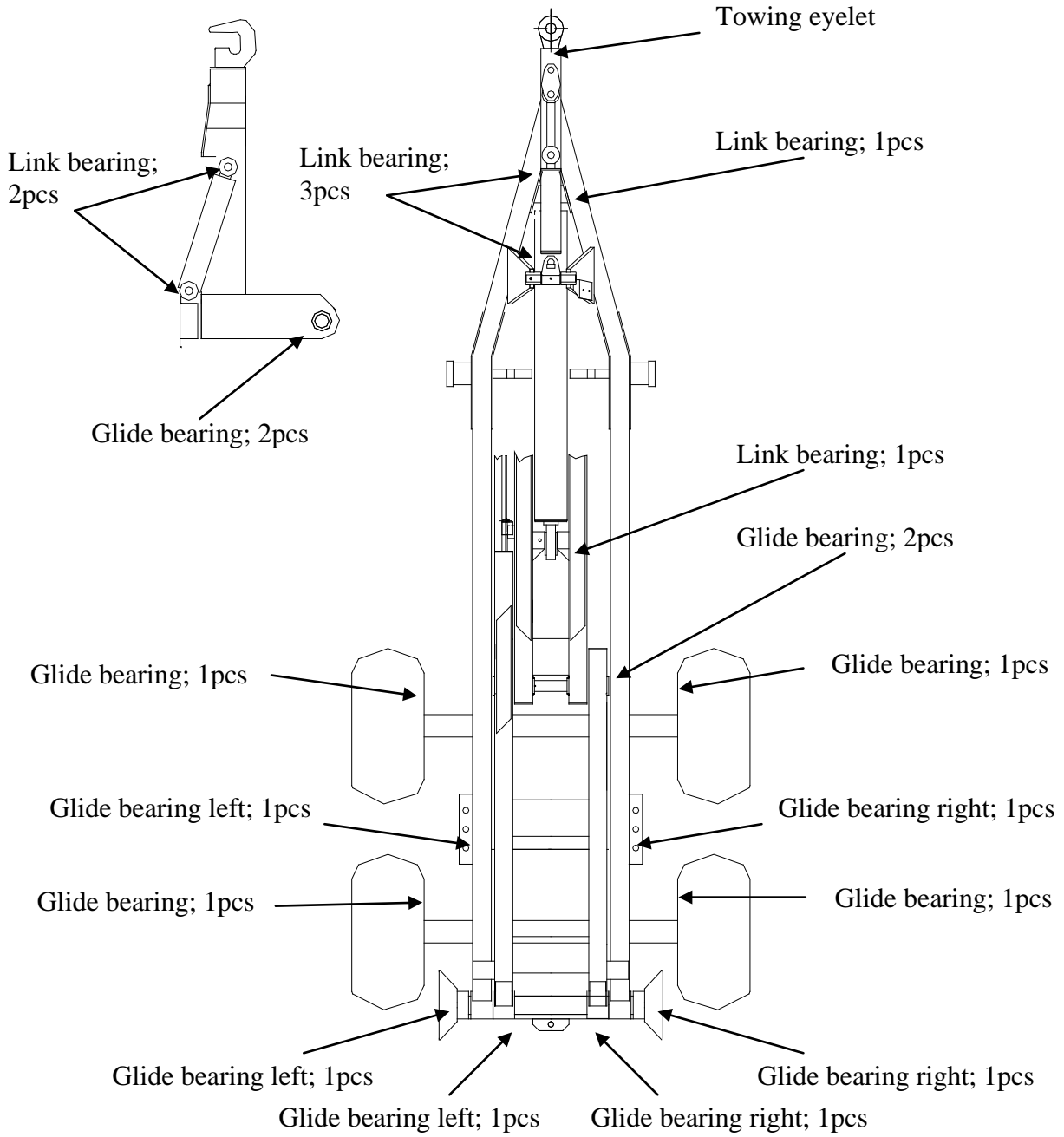

Figure 39. Lubrication points

## 5.3. SPARE PARTS

### 5.3.1. Back and Hook frames

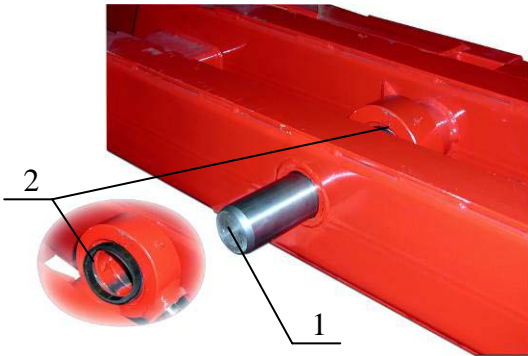

Figure 40. Cylinder coupling



Figure 41. Back and hook frame coupling



Figure 42. Foldable tower

Back, rolling frame and foldable tower spare parts

Table 12.

Pos.	Art. No.	Description	Note
1	37203110	Axle	
2	37203115	Distance ring	
3	37203140	Axle	
4	37204110	Axle	
5	37211115	Axle	
6	37211120	Axle	
7	37211180	Distance ring	



### 5.3.2. Bogie

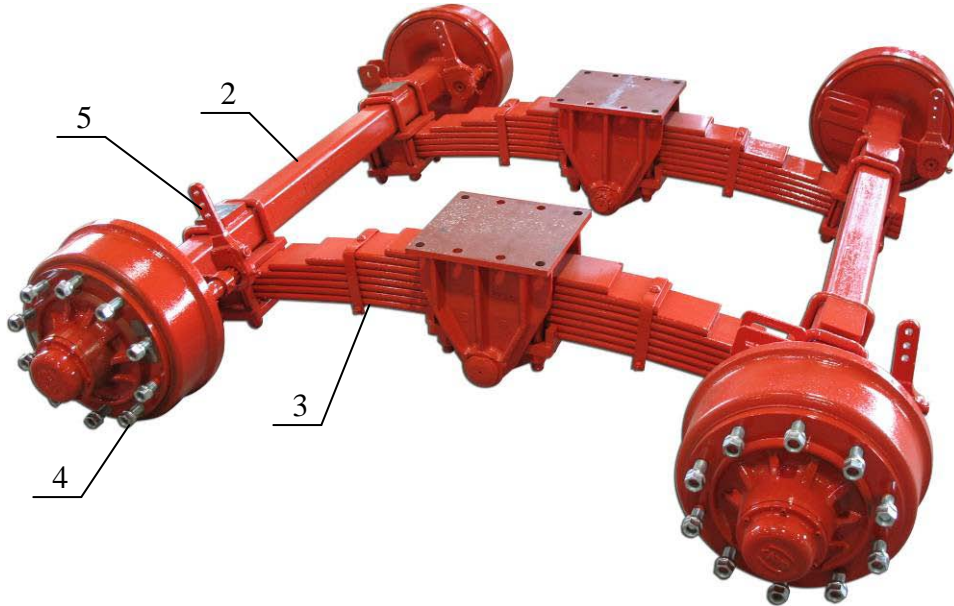

Picture shows : Bogie suspension 20t

*Figure 43. Spring suspension bogie*

Spring suspension bogie spare parts

Table 13.

Pos.	Art. No.	Description	Note
	916827	Spring suspension bogie comp. 17t	
2	916827 AXLE	Axle	
3	916827 BOGIE	Spring suspension	
4	916480	Ring nut M20	
5	916466	Brake arm	

### 5.3.3. Frame locking

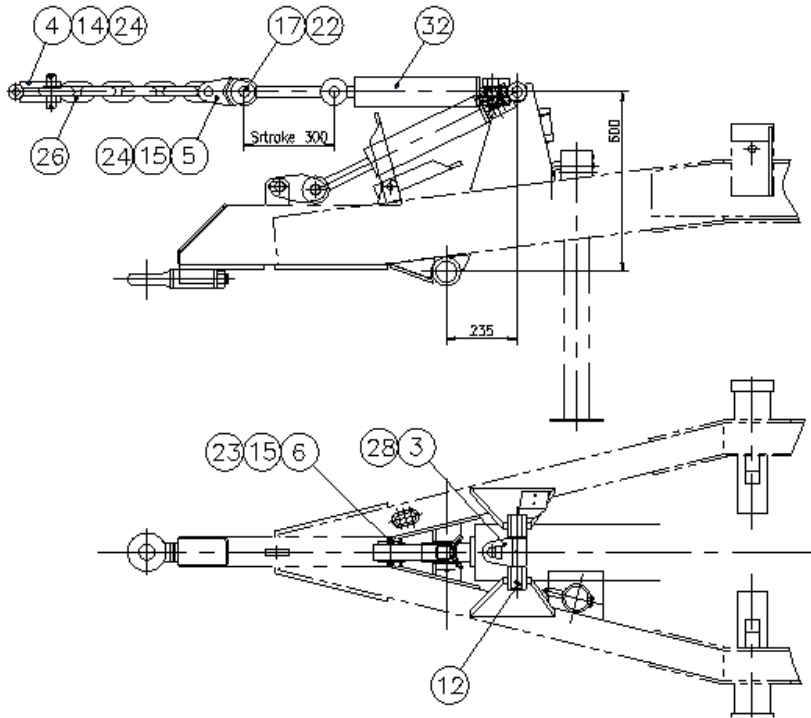

Figure 44. Frame lock

Frame locking spare parts

Table 14.

Pos.	Art. No.	Title
	391014/1215	Hydr. frame lock system
3	37121520	Link
4	37121525	Link
5	37121530	Link
6	37121535	Support
12	37121522	Axle
14	37121527	Pin
15	37121532	Pin
17	37024378	Pin
22	908110	Split 4x45 DIN 94
23	911250	Stopper ring 20 DIN 471
24	920230	Locking pin 6x40 DIN 11023
26	920223	Chain (8 link)
32	313134	Cylinder 90x40x300

### 5.3.4. Steering rollers



Figure 45. Steering roller spare parts

Rollers spare parts

Table 15.

Pos.	Art. No.	Description	Note
1	320340/320341	Roller comp. (left, right)	
2	37203045	Axle	
3	909115	Slide bearings Ø100	
4	320360	Tipper axle	

### 5.3.5. Changing operating unit

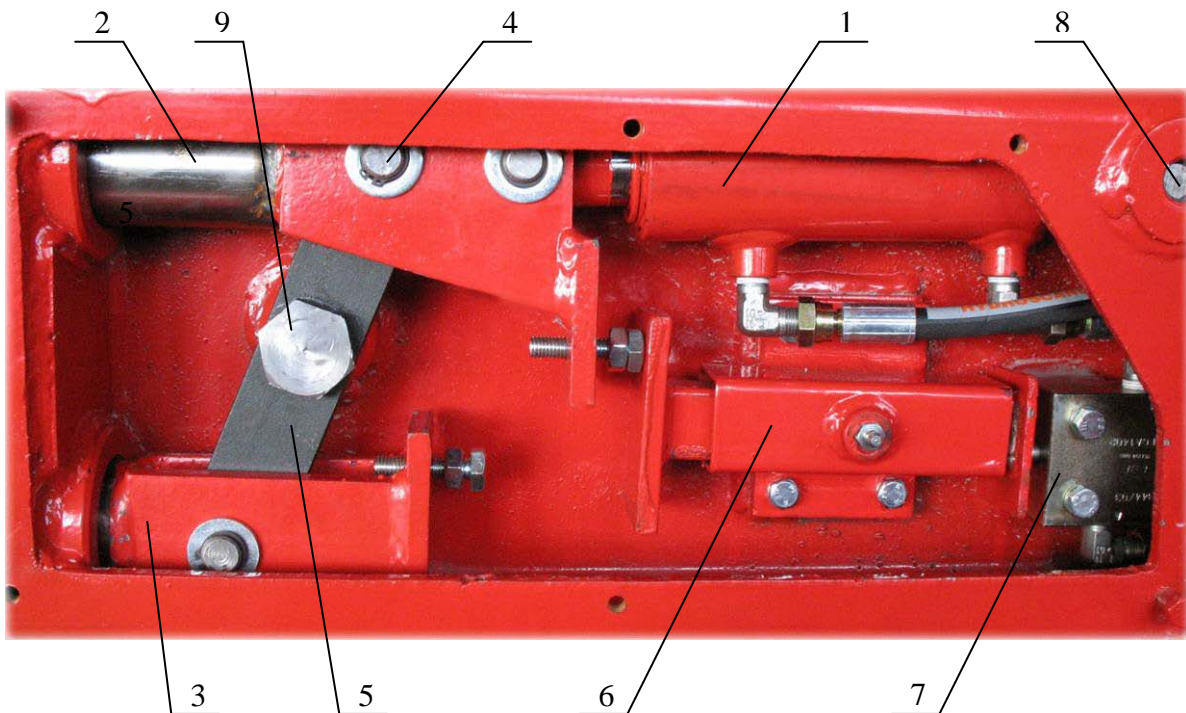

Figure 46. Changing operation unit

Changing operating unit spare parts

Table 16.

Pos.	Art. No.	Description	Note
	37211007	Changing unit compl.	
1	913230	Operation changing cylinder	
2	37211787	Pin	
3	37211788	Pin	
4	37211789	Axle	
5	37211790	Lever	
6	37211791	Pusher	
7	913640	End of stroke valve	
8	37211792	Axle	
9	37211793	Axle	

### 5.3.6. Hydraulic components

For hydraulic diagram see chapter 3.4.1

Hydraulic components spare parts

Table 17.

Pos.	Art. No.	Description	Note
7	913255	Tipping / Rolling cylinder 160/80-1570 with pilot operated valve	
	37913255	<u>Sealing kit for hydraulic cyl. 160/80</u>	
	37913256	<u>Front bush for hydraulic cyl. 160/80</u>	
	37913258	<u>Piston for hydraulic cyl. 160/80</u>	
8	913238	Tower cylinder 125/63-250	
	37913240	<u>Sealing kit for hydraulic cyl. 125/63</u>	
	37913241	<u>Front bush for hydraulic cyl. 125/63</u>	
	37913243	<u>Piston for hydraulic cyl. 125/63</u>	
18	913210	Brake cylinder 40/25-55	
	37913210	<u>Sealing kit for hydraulic cyl. 40/20</u>	
	37913212	<u>Front bush for hydraulic cyl. 40/20</u>	
	37913213	<u>Piston for hydraulic cyl. 40/20</u>	
11	913230	Operation changing cylinder 50/32-70	
	37913230	<u>Sealing kit for hydraulic cyl. 50/32</u>	
	37913232	<u>Front bush for hydraulic cyl. 50/32</u>	
	37913233	<u>Piston for hydraulic cyl. 50/32</u>	
9	913640	End of stroke valve	
10	915200	Pilot operated check valve	
11	915201	Pilot operated double check valve	
12	17-100100.00	Pushing cylinder	

For frame lock hydraulic diagram see chapter 3.4.2

Frame lock hydraulic components spare parts

Table 18.

Pos.	Art. No.	Title
1	313134	Cylinder 90/40-300
	37313940	<u>Sealing kit for hydraulic cyl. 90/40</u>
	37313942	<u>Front bush for hydraulic cyl. 90/40</u>
	37313944	<u>Piston for hydraulic cyl. 90/40</u>
2	915275	Manometer
3	915271	Pilot operated check valve
4	915266	Pressure reducing/relieving valve
6	915265	Manifold
7	914570	Bayonet coupling male
8	9145702	Bayonet coupling female

### 5.3.7. Cylinder description

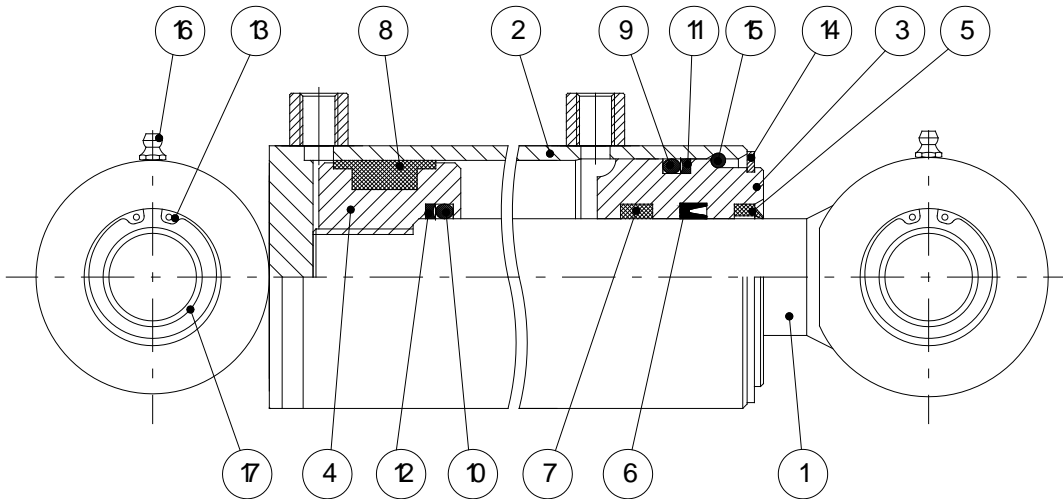

Figure 48. Cylinder description

Table 19.

Pos.	Description	Note
1	Piston rod	Spec. order
2	Cylinder tube	Spec. order
3	Front bush	
4	Piston	
5	Scrape ring	Included in sealing kit
6	Sealing	Included in sealing kit
7	Bush ring	Included in sealing kit
8	Sealing	Included in sealing kit
9	O-ring	Included in sealing kit
10	O-ring	Included in sealing kit
11	Sealing	Included in sealing kit
12	Sealing	Included in sealing kit
13	Locking ring	
14	Locking ring	Included in sealing kit
15	Locking ring	Included in sealing kit
16	Grease nipple	
17	Link bearing	

### 5.3.8. Electrical system

For electrical scheme see chapter 3.3 Pos. 5-8 concerning spare parts table is not shown in electrical scheme.



Figure 49. Rear lamp

Electrical spare parts.

Table 20.

Pos.	Art. No.	Description	Note
1	920764L/R	Rear light, right or left	
1	920766L/R	Rear light with reversing light – special, right or left	
2	920770	Border light 111x40 (orange) - special	
3	920715	Cable terminal	
4	920695	Cable Connector 7 pools (male)	
5	920180	Cable Connector 7 pools (female) -special	
6	920723	Bulb 12V, 5W	
7	920745	Bulb 12V, 21W	
8	920725	Bulb 12V, 10W	

### 5.3.9. Electrical on-off system

For electrical on-off system diagram see chapter 3.3.2

Electrical on - off components spare parts (see also chapter 5.3.6)

Table 21.

Pos.	Art. No.	Title
1	940810	Release valve
2	940815	Security valve
3	940820	Logic valve
4	940825	4-way valve
5	940830	Valve block
6	940835	4-way valve
7	915181E	Electric on-off control unit
8	91581CS	Cable set
9	91581ES	Electrical switch
10	91581RP	Rubber protection
11	915181CC	Cable connector

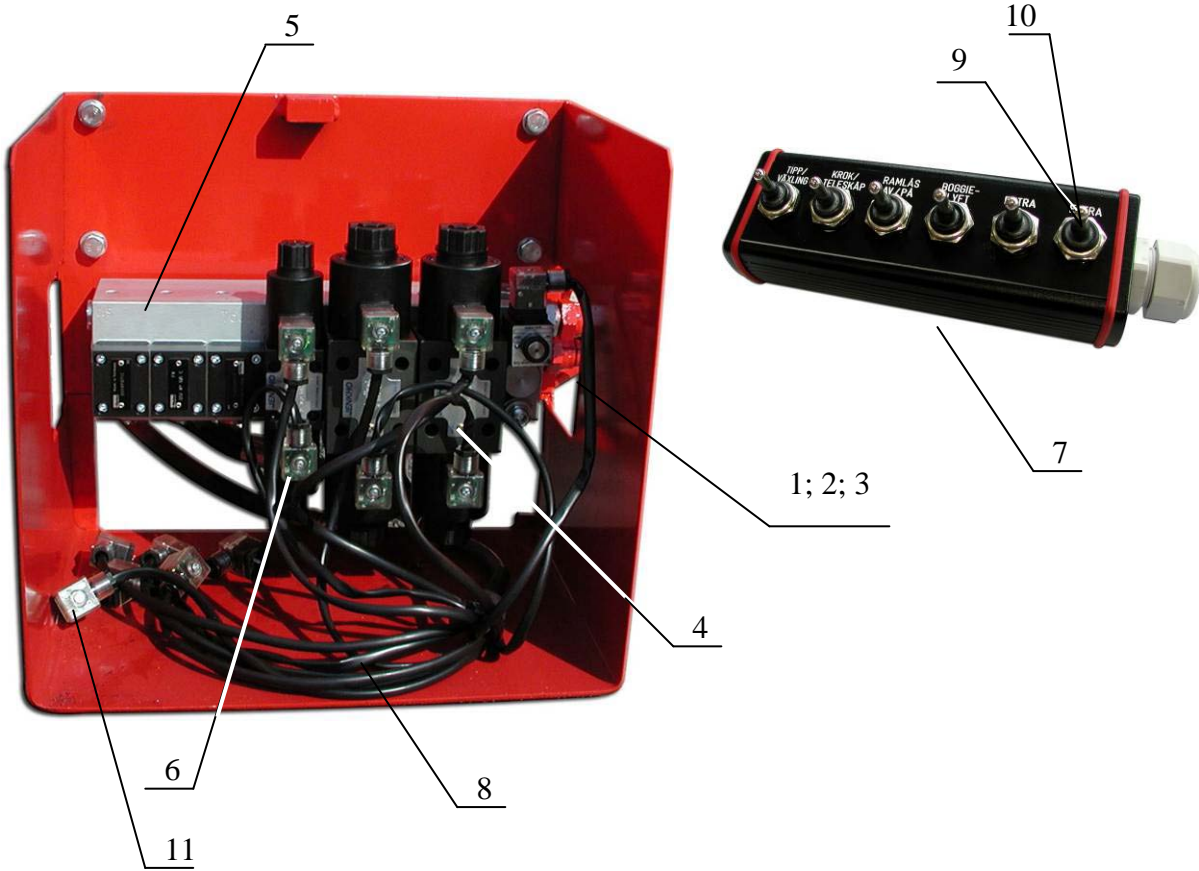

Figure 50. Electrical on – off system



### 5.3.10. Other parts

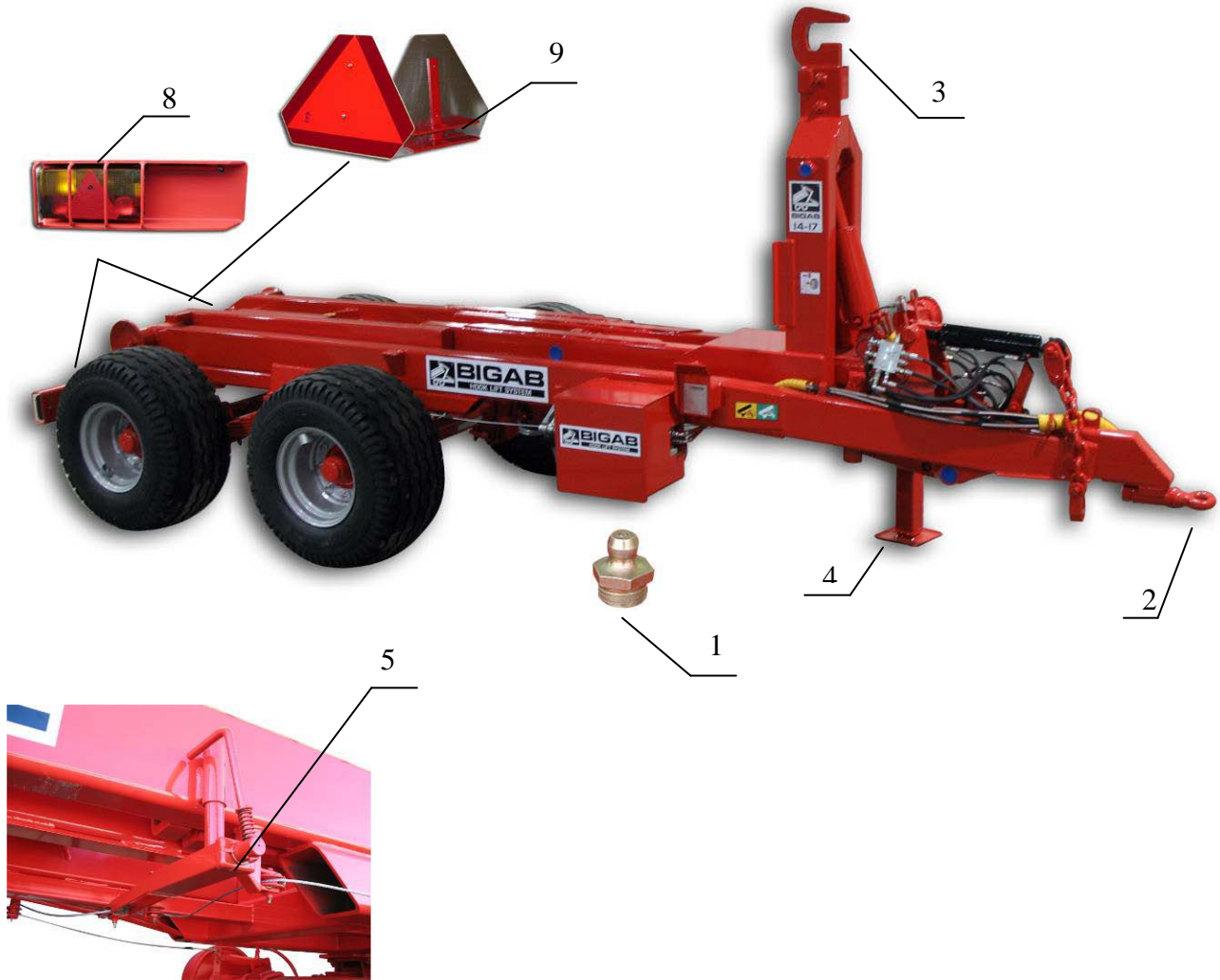

Figure 51. Other spare parts

Other spare parts  
Table 22.

Pos.	Art. No.	Description	Note
1	930105	Grease nipple	
2	920111	Towing eyelet	
3	37221002	Hook	
4	920822H	Hydraulic Support leg	
5	700617	Parking brake	BPW
6	37203085	Security post	
8	920150	LBF board	
9	920155	Reflector 3-angle (red)	

## 6. TROUBLESHOOTING

These troubleshooting instructions are provided to help you to determine the cause for a malfunction.

### Electrical equipment troubles

Fault symptoms	Reason and action
Lights fault	Lamp born out. Replace lamp.
	Check and clean electrical connectors.
Wire broken.	Check and repair wire.

### Hydraulic equipment troubles

Fault symptoms	Reason and action
Too slow lift of implement or cylinders will not return from working position to neutral.	Valve stuck. Clean valve parts. Valve should move freely without seizure.
Ingress air into hydraulic system.	Locate leaky point and eliminate defect. Check oil level.
Excessive leakage of oil in pump.	Replace pump
Low oil pressure.	Adjust oil pressure.
Hydraulic cylinder piston packing out of order.	Replace packing.
Hydraulic system noise	Air entrapped into system. Locate air suction and eliminate defect.
Distributor safety valve maladjusted.	Adjust valve.
Oil leaking	Replace ruptured hose or tighten hose connection.
Oil leaks through final drive labyrinth seals.	Rubber packing between track sprockets and hub or labyrinth seals worn. Replace rubber rings.

### Brake system troubles

Fault symptoms	Reason and action
Poor operation of brakes Greasy or worn-out drive disk linings.	Wash linings with gasoline or replace from spares
Maladjustment of brake control linkage.	Adjust brake control linkage.