

INSTRUCTION BOOK

FARMA T 7

SERVICE AND SPARE PARTS

TABLE OF CONTENTS

1	INTRODUCTION	1
2	TECHNICAL SPECIFICATION.....	2
	2.1 CONSTRUCTION OF THE TRAILER	2
	2.2 SPAREPART LIST FOR FARMA TRAILER T8.....	3
	2.3 HYDRAULIC CYLINDERS	4
	2.4 TECHNICAL DATA.....	5
3	OPERATING INSTRUCTIONS.....	6
	3.1 SAFETY	6
	3.2 INSTRUCTIONS FOR SAFE OPERATION	7
	3.3 WORKING AT EXTREME CONDITIONS	8
4	MAINTENANCE INSTRUCTIONS.....	8
	4.1 SAFETY	8
	4.2 LUBRICATION	9

1 INTRODUCTION

This manual deals with the **T 8** forest trailer and contains all the operating and maintenance instructions you need for using the trailer safely and correctly.

Even if you are experienced user of this kind of equipment, read this manual carefully.

It contains information that enables the trailer to be used efficiently and safely. Make sure that this trailer corresponds to your demands.

Regular maintenance is essential for troublefree, efficient and economical utilization.

It is the operator duty to familiarize and obey all safety precautions and instructions carefully.

2 TECHNICAL SPECIFICATION

2.1 CONSTRUCTION OF THE TRAILER

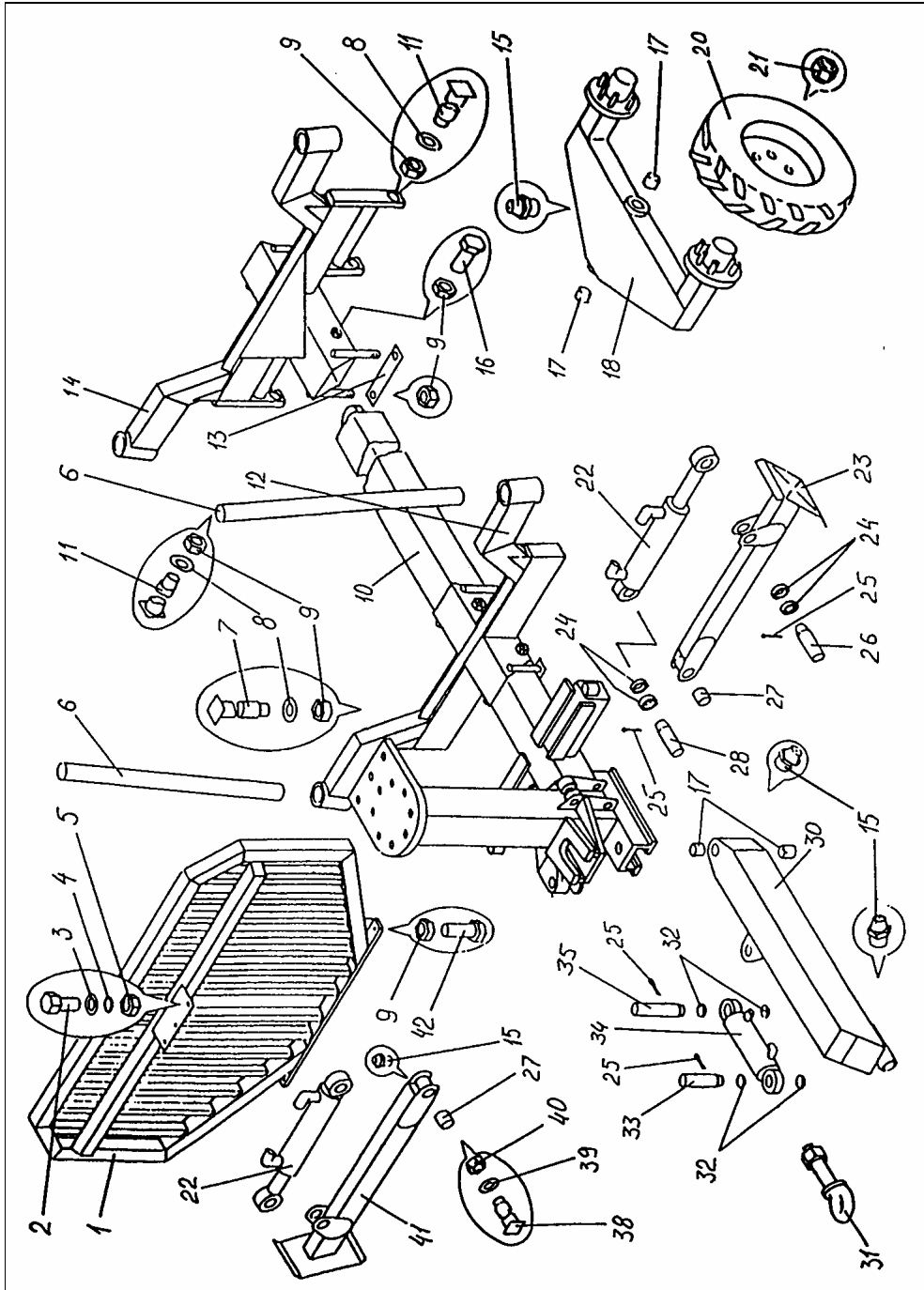

2.2 SPAREPART LIST FOR FARMA TRAILER T8

Production no FMW 11

Pos no	Art no	Number	Sparepart	Dimension	Pcs
1	11001	F11-080000.000	Backwall		1
2	11002		Bolt	M12x40	3
3	11003		Plane washer	ø12	3
4	11004		Spring washer	ø12	3
5	11005		Nut	M12	3
6	11006	F13-150000.000	Pin		4
7	11007	M13-000030.000-060	Axle-bolt		1
8	11008	M13-000000.001	Plane washer	ø24	3
9	11009		Nut	M24	17
10	11010	F11-070000.000	Frame / Chassi		1
11	11011	M13-000030.000-030	Axle-bolt		2
12	11012	F11-170000.000	Material holder		1
13	11013	F13-062000.003-010	Lock-plate		4
14	11014	F11-061000.000	Wheel support		1
15	11015		Grease nipple	1/8 inch	8
16	11016		Bolt	M24x60	4
17	11017		Glide-bearing	PAP5040P10	6
18	11018	M13-090000.000-010	Boggi sides		2
20	11019		Wheels	11,5/80-15,3	4
21	11020		Wheel nut		24
22	11021	M14-100100.000-020	Hydraulic cylinder	63/32-300	2
23	11022	F11-140000.000-010	Stabilizer leg		1
24	11023	M14-000000.001	Distance ring		8
25	11024		Split pin	ø4x60	6
26	11025	M14-000000.002-040	Axle-bolt		2
27	11026		Glide-bearing	PAP2530P10	4
28	11027	M14-000000.002-030	Axle-bolt		2
30	11028	F11-050000.000	Pull-beam		1
31	11029	F13-000010.000	Pull-loop	12 ton	1
32	11030	M13-000000.017	Distance ring		4
33	11031	M13-000000.002-020	Axle-bolt		1
34	11032	F11-100100.000	Hydraulic cylinder	90/40-100	1
35	11033	M13-000000.002-040	Axle-bolt		1
38	11034	M14-010050.000-040	Axle-bolt		2
39	11035		Plane washer	ø20	2
40	11036		Nut	M20	2
41	11037	F11-140000.000	Stabilizer leg		1
42	11038		Bolt	M24x80	2
43	11039	RF11.7,5	H-hose frame steering	L=2460	1
44	11040	RF11.7,5	H-hose frame steering	L=2700	1
45	11041	S.7,5	H-hose for stabilizer	L=3500	2
46	11042	S.7,5	H-hose for stabilizer	L=3350	2

2.3 HYDRAULIC CYLINDERS

Sparepart list for hydraulic cyl 90/40x100
 Frame steering cyl for trailer T 7; T 8
 Production no F11-100100.000

Pos no	Art no	Number	Sparepart	Dimension	Pcs
1	56101	F11-100120.000	Piston rod		1
2	56102	F11-100110.000	Tube		1
4	56102	F13-100100.001	Front bush		1
5	56103	F13-100100.002	Piston		1
8	56103		Scrape ring	AS40-50-7-10	1
9	56104		Sealing	NI 300 40-55-10	1
10	56104		Bush	DFI 40-45-5,5	1
11	56105		Sealing	SIMKO 5x2 90-70-33,8	1
13	56105		O-ring	79,2x5,7	1
14	56106		O-ring	40,2x3,0	1
15	56106		Sealing	SRA 90-5,1-1,5	1
16	56107		Sealing	SRI 40-2,6-1,5	2
19	56107		Lock-ring	SGH 55	2
20	56108		Lock-ring	SGA 87	1
21	56108		Lock-ring	N°72290	1
23	56109		Grease-nipple	1/8"	2
24	56109		Joint bearing	GE35ES	2

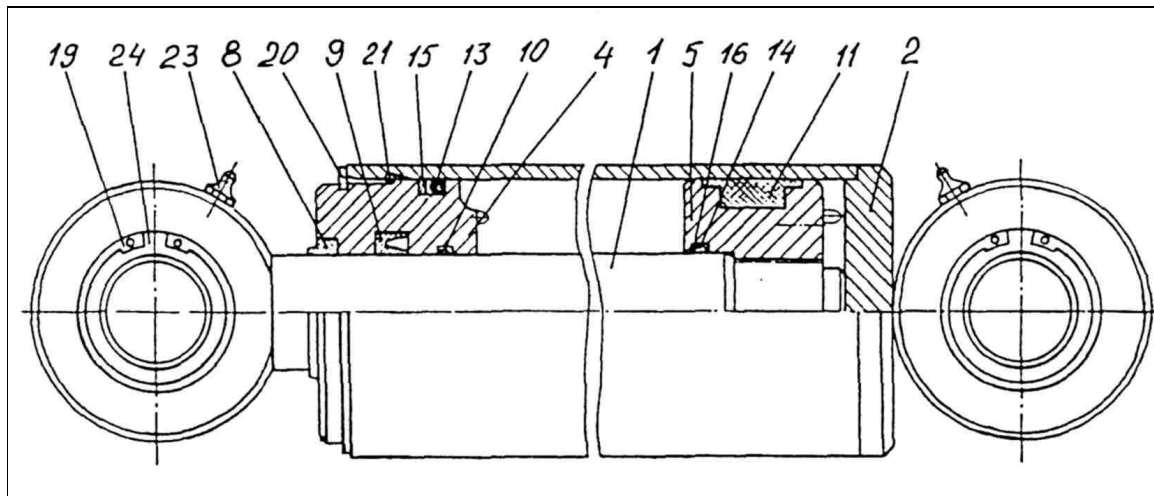

Sparepartlist for Hydraulic-cylinder 63/32-300
 Stabilizer-cyl for Farma trailer T 6;T 7; T 8
 Production no M14-100100000-020.

Pos nr	Art no	Number	Sparepart	Dimension	Pcs
1	55601	M13-100320.000-020	Piston rod		1
2	55602	M14-100110.000-020	Tube		1
4	55603	M13-100300.001	Front bush		1
5	55604	M13-100300.002	Piston		1
8	55605		Scrape-ring	AS 32-45-7-10	1
9	55606		Sealing	NI300 32-47-10	1
10	55607		Buch	DFI 32-35,1-4,0	1
11	55608		Sealing	Simco 5x2 63-47-29,8	1
13	55609		O-ring	52,2x5,7	1
14	55610		O-ring	32,2-3,0	1
15	55611		Sealing	SRA 63-5,1-1,5	1
16	55612		Sealing	SRI 32-2,6-1,0	2
19	55613		Lock-ring	SGH 42	2
20	55614		Lock-ring	SGA 60	1
21	55615		Lock-ring	N 72240	1
23	55616		Grease-nipple	1/8"	2
24	55617		Joint bearing	GE25ES	2

2.4 TECHNICAL DATA

FARMA TRAILER	7 t
Loading area, m ²	1,8
Ground clearance, mm	510
Center beam, mm	140x140x8
Steerable towbar	one cyl
Axle, mm	60x60
Length, m	5,6
Width, m	1,9
Wheels	11,5/80-15,3
Loader weight, kg	1400

3 OPERATING INSTRUCTIONS

3.1 SAFETY

- ❑ Read the manual before operating the trailer. Neglecting the instructions can cause danger to operator and machine.
- ❑ Operator must have sufficient training for using this machine.
- ❑ Do not use the trailer until you are familiar with the controls.
- ❑ Before loading works, ensure there is no one in danger zone (20 m).



DON'T FORGET TO LIFT THE SUPPORT LEGS UP BEFORE MOVING TO ANOTHER PLACE.

- ❑ Operator must have full visibility all over working area.
- ❑ The vehicle must be on stable ground and positioned securely. Support legs must be used while loading to prevent the trailer tipping over.
- ❑ Use vehicles parking brakes during the loading.
- ❑ Do not exceed maximum loading values.

3.2 INSTRUCTIONS FOR SAFE OPERATION

SUPPORTING THE TRAILER

- Always engage the base machines parking brakes before loading. If necessary put some obstacles in front of wheels.
- Always use support legs. Make sure the trailer is situated at firm terrain.



DO NOT USE SUPPORT LEGS FOR LIFTING THE LOAD. USE SUPPORT LEGS ONLY FOR SUPPORTING THE TRAILER.

MANIPULATING THE HYDRAULIC FUNCTIONS



NEVER CONTROL THE HYDRAULIC FUNCTIONS FROM ONE EXTREME POSITION TO ANOTHER WITH SPEED! THIS MAY CAUSE OVERTURNING THE TRAILER.

- Avoid loading on a slanted ground or at least work with extreme cautiousness.
- When working on a slanted surface load less than usual.

ALWAYS ENGAGE THE BASE MACHINES PARKING BRAKES BEFORE LOADING WORKS. IF NECESSARY PUT SOME OBSTACLES IN FRONT OF WHEELS.



3.3 WORKING AT EXTREME CONDITIONS

Recommended working temperature range for trailer is -30°C up to +40°C.

Note that working at low temperatures accelerates hydraulic gaskets wearing and increases hydraulic hoses exposure to damages and steel constructions exposure to brittle fracture. Before start working at cold conditions let the oil circulate freely through system a few minutes.

Slowly drive every action through several times so that gaskets come pliable before they receive full pressure.

At exceptionally warm conditions beware of hydraulic oils excessive heating. Too high oil temperature (higher +80°C) degrades oil and damages gaskets.

4 MAINTENANCE INSTRUCTIONS

4.1 SAFETY



READ THE MAINTENANCE INSTRUCTIONS BEFORE SERVICE OR MAINTENANCE WORKS. DO NOT ATTEMPT TO PERFORM SUCH MAINTENANCE WORKS WHICH YOU DO NOT FULLY UNDERSTAND

- Repair all safety endangering defects immediately.
- Check that the trailer is on a level and stable ground.
- Use vehicles parking brake during maintaining the trailer. Make sure that nobody can unnecessarily have access to trailers or vehicles controls.
- Never attempt to do maintenance works on the hydraulic system before you are sure there is no pressure.
- Do not tighten or repair a leaking hydraulic couplings while the system is pressurized.
- Never attempt to localize a leakage from hoses or connections by feeling with hand. The high pressure oil jet can penetrate skin and cause serious burns and damages. High pressure oil is also highly flammable.
- Do not work under such device that is sustained only by hydraulics. During maintenance use supports.
- Avoid getting oil into eyes. Use safety goggles and gloves.

4.2 LUBRICATION

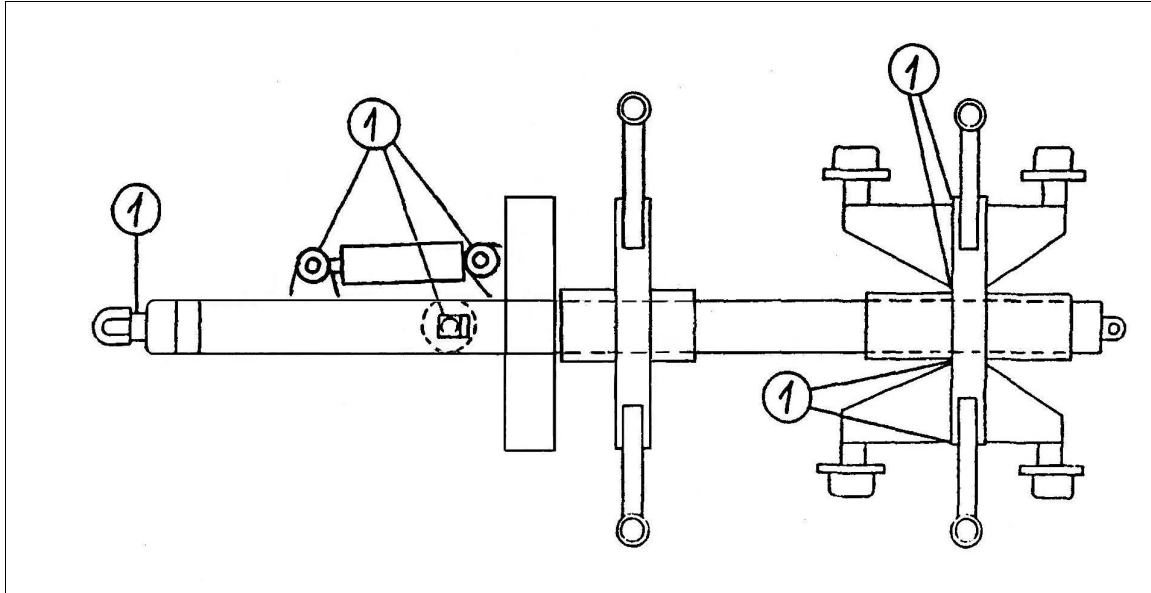

Recommended grease BP LS-EP2 , I 21M



**PAY SPECIAL ATTENTION TO THE TOWBAR CYLINDER.
GREASE IT AFTER EVERY 50 WORKING HOURS.**